

FS-*i* Series

Check Weighing Scales
Options

INSTRUCTION MANUAL

OP-02

OP-03

OP-04



AND
A&D Company, Limited

Contents

1. OP-02 BATTERY	3
1-1. Using the OP-02 SLA Battery	3
2. OP-03 RS-232C / RELAY OUTPUT	5
2-1. Installation	5
2-2. OP-03 Specifications	6
2-3. Command Mode.....	8
2-4. Using UFC (Universal Flex Coms) function.....	12
3. OP-04 RS-422 / 485 / RELAY OUTPUT	15
3-1. Installation	15
3-2. OP-04 Specifications	16
3-3. Data output.....	17

This Manual and Marks

All safety messages are identified by the following, "WARNING" or "CAUTION", of ANSI Z535.4 (American National Standard Institute: Product Safety Signs and Labels). The meanings are as follows:

 WARNING	A potentially hazardous situation which, if not avoided, could result in death or serious injury.
 CAUTION	A potentially hazardous situation which, if not avoided, may result in minor or moderate injury.



This is a hazard alert mark.

Note This manual is subject to change without notice at any time to improve the product. No part of this manual may be photocopied, reproduced, or translated into another language without the prior written consent of the A&D Company.

Product specifications are subject to change without any obligation on the part of the manufacture.

Copyright©2006 A&D Company, Limited

1. OP-02 BATTERY

1-1. Using the OP-02 SLA Battery

- ❑ The scale can be operated with an SLA (Sealed Lead Acid) battery that will be commercially available.
- ❑ The scale (with no other options) can be operated with a fully charged battery for;
 - LCD backlight OFF and Comparator light OFF: approximately 80 hours
 - LCD backlight OFF and Comparator light ON: approximately 55 hours
 - LCD backlight ON and Comparator light ON: approximately 25 hours
- ❑ The battery will take about 15 hours to be fully charged.
- ❑ The battery life will vary depending on how the scale is used, the ambient temperature and so on.



- ❑ Use a Yuasa Battery NP4-6 (6V, 4Ah).
- ❑ There will be risk of explosion if the battery is connected improperly or replaced with the incorrect type.
- ❑ Dispose of a used battery according to the local laws and regulations.

Installing the battery

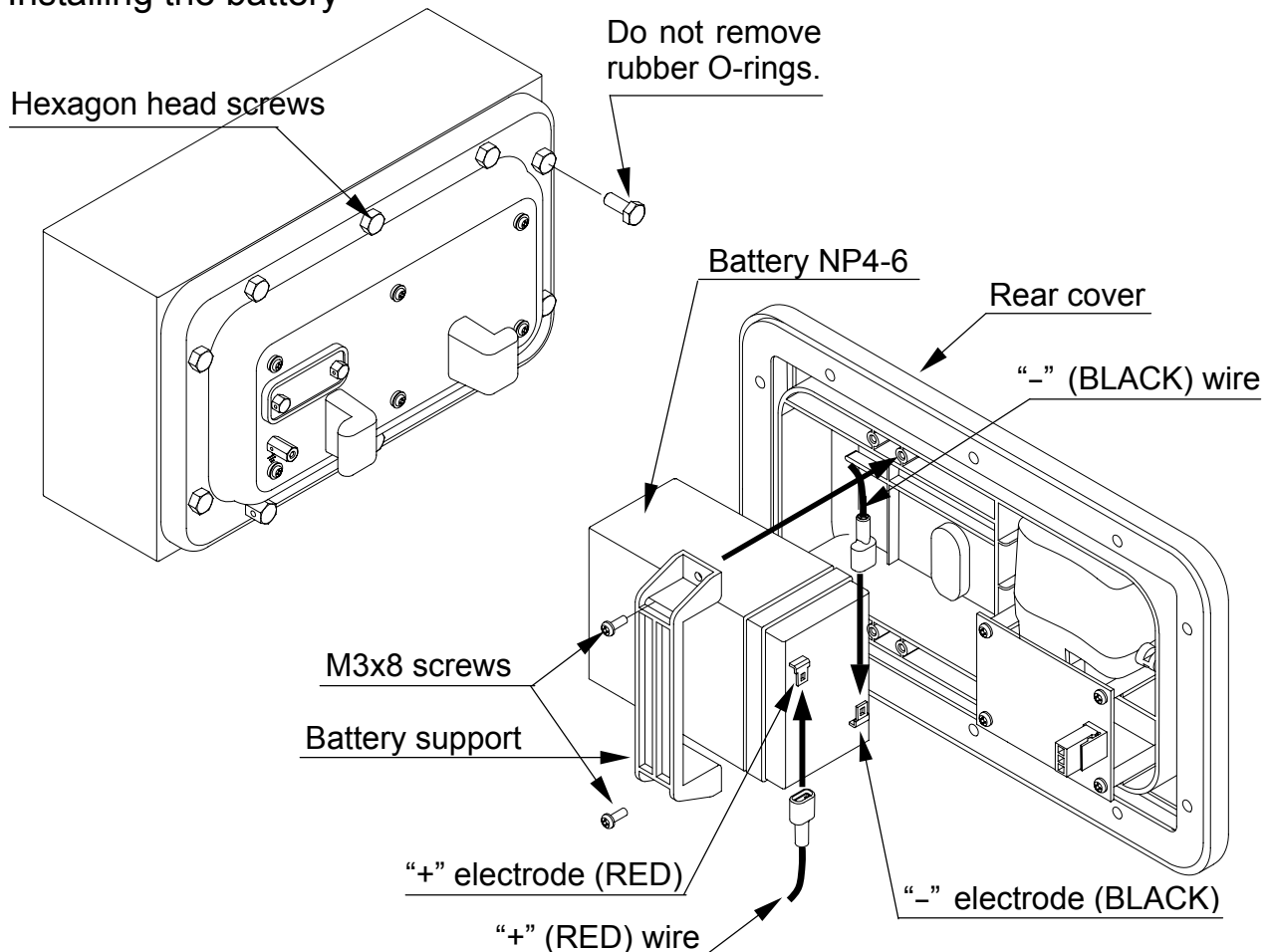

1. Disconnect the main power cord from the outlet.
2. Remove the ten hexagon head screws and open the rear cover.
- ⚠ **Take care not to drop the rear cover or the wires connecting between front display and rear cover will be damaged.**
3. Loosen the screws fixing the battery support and remove it.
4. Connect the wires inside the display pod to the battery.
- ⚠ **Be sure to connect RED wire to positive (+ / RED) terminal and BLACK wire to negative (- / BLACK) terminal. Or there is a risk of explosion.**
5. Place the battery into the rear cover and fix with screws and battery support that removed at step 3 above.
6. Attach the rear cover to the front display firmly using the ten hexagon head bolts.
7. Connect the main power cord to the outlet.
8. Press the ON/OFF key and check that the scale works normally.
9. Disconnect the main power cord again and check that the scale still works.

Charging the battery

- When the weight display shows “L b I”, the battery voltage is low in voltage and should be recharged. Connect the main power cord to the outlet. The charging process will start while the scale is powered on or not.
- When the battery is getting close to the low battery, the annunciator (PRECAUTION AGAINST LOW BATTERY) will come on. Prepare to charge the battery.
- The scale can be used while the battery is charging. After fully charged, the scale will change the charging process to trickle charge automatically.
- The battery cannot be charged with the OP-04 in operation. Turn the power off to charge.
- Charge the battery at a temperature between 0°C (32°F) and 40°C (104°F). Preferably 5°C (41°F) ~ 35°C (95°F) is recommended.**
- Charge the battery when using for the first time.**
- The battery must be recharged regularly if the scale is not used for a long period of time. Every 3 months in a warmer area and every 6 months in a cooler area will be needed.**

2. OP-03 RS-232C / RELAY OUTPUT

This interface allows the FS-*i* series to be connected with a multifunction printer or a personal computer, and the relay outputs for comparator result are obtained.

- The OP-03 unit includes an interface board, a connector cable, a cable gland and two screws (M3x6).

2-1. Installation

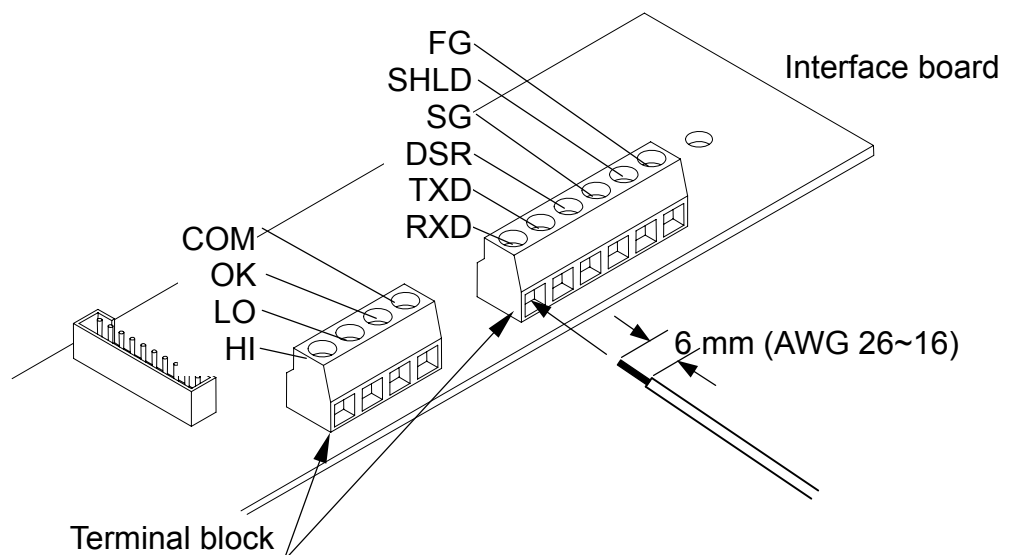
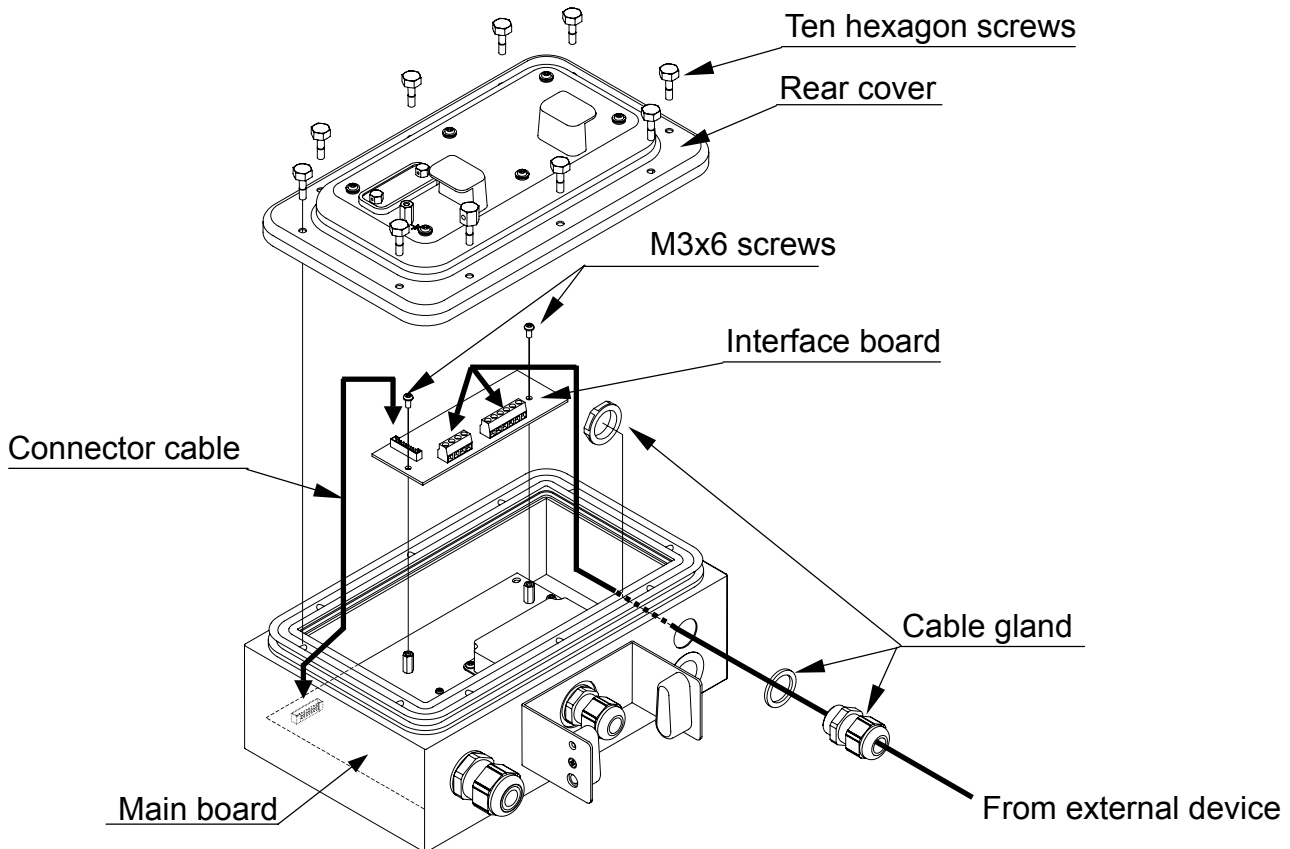

1. Disconnect the main power cord from the outlet.
2. Remove the ten hexagon screws and open the rear cover.
3. Connect the cable from external device through the cable gland to the terminal blocks on the interface board. Also connect a yellow/green wire inside the display pod directly to "FG" on the terminal block.

⚠ Take care not to drop the rear cover or the wires connecting between front display and rear cover will be damaged.

4. Connect the connector cable included in the OP-03 to the connectors on the interface board and the main board inside the display pod.
5. Fix the interface board with 2 M3 x 6 screws included in the OP-03.
6. Tighten the cable gland and attach the rear cover to the front display firmly using the ten hexagon bolts.
7. Connect the main power cord to the outlet.
8. Set the function parameters F04, F05, F06, F18, F19 and F20 according your application.

The OP-03 RS-232C must have settings F18-00 and F19-0.

2-2. OP-03 Specifications

RS-232C Specification

Transmission form	Asynchronous, bi-directional, half-duplex
Data format	Baud rate: 2400, 4800, 9600 bps
(non-parity)	Data: 7 bits + parity 1bit (even / odd) or 8 bits
	Start bit: 1 bit
	Stop bit: 1 bit
	Code: ASCII
	Terminator: C _R L _F

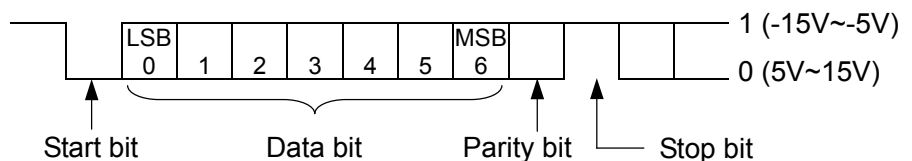

Maximun rating of the Relau Outoput

The maximum rating of the replay output is as follows.

- Maximum voltage: 50V DC
- Maximum current: 100 mA DC
- Maximum ON resistance: 8 Ω

Circuit diagram

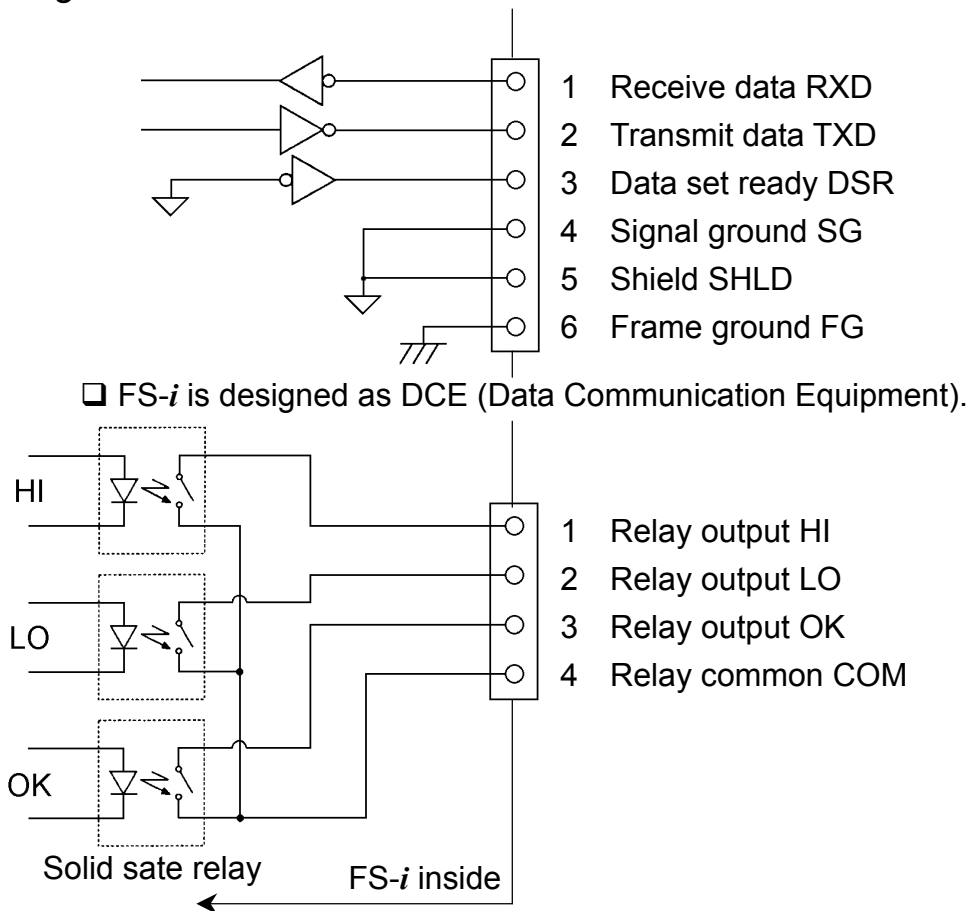

Data format

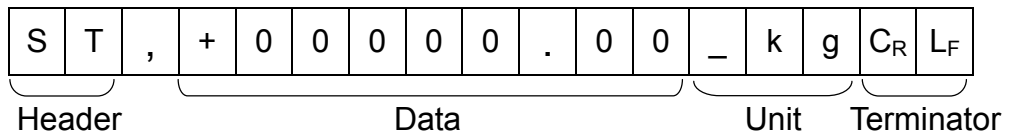

- There are 3 headers for the weighing data.

ST: Stable weighing data
 US: Unstable weighing data
 OL: Out of weighing range

- The data consists of 9 characters including polarity and decimal point.

- There are 5 units.

_ k g: Weighing unit "kg"
 _ _ g: Weighing unit "g"
 _ l b: Weighing unit "lb"
 _ o z: Weighing unit "oz"
 _ _ %: HI/LO limit % (F07-2)

- Example of data

Weighing data "kg" (+)	S	T	,	+	0	0	1	2	.	3	4	5	_	k	g	C _R	L _F
Weighing data "g" (-)	S	T	,	-	0	0	0	0	1	2	3	4	_	_	g	C _R	L _F

Out of range (+)

O	L	,	+	9	9	9	9	9	9	9	9	_	k	g	C _R	L _F
---	---	---	---	---	---	---	---	---	---	---	---	---	---	---	----------------	----------------

Data output mode (F06)

Stream Mode (F06-0)

Data is sent continuously. The data-update rate is approximately 20 times per second. But for 2400 bps, it is too slow to send 20 times. If necessary, set the baud rate 4800 bps or more.

Command Mode (F06-1)

The scale is controlled by commands that come from an external device, computer etc. See “2-3. Command mode” in detail.

Print Key Mode (F06-2)

When the weight display is stable, data is sent by pressing the **PRINT** key. The PRINT annunciator will turn on for a short while when the data has been sent.

Auto-print Mode + data (F06-3)

Data is sent if the weight display is stable at +5d (d = weighing display division) and above. The next transmission can not occur until after the weight display falls below +5d.

Auto-print Mode +/- data (F06-4)

Data is sent if the weight display is stable at ±5d (d = weighing display division) and above/below. The next transmission can not occur until after the weight display falls between -5d and +5d.

Baud Rate (F04)

Select the baud rate according to the device to be connected.

2400 bps (F04-0)

Select 2400 bps to connect with an AD-8121.

4800 bps (F04-1)

9600 bps (F04-2)

2-3. Command Mode

In the command mode, the scale is controlled by commands that come from an external device, computer etc.

Command List

Command	Definition	Notes
Q	Send data immediately.	
Z	Zero the scale when the weight is stable.	Same as the ZERO key.
T	Tare the scale when the data is stable.	Same as the TARE key.
U	Switch the weighing unit.	Same as the UNITS key.
D	Switch the analog sweep display mode.	Same as the DISP. key.
PT	Set a known (preset) tare weight.	Set “+” and 6 digit number without decimal point.

Command	Definition	Notes
CT	Clear tare weight.	Including preset tare.
?PT	Send a preset tare weight in-use.	
?TR	Send a tare weight in-use.	
?OK	Send a target weight in-use.	
?HI	Send a HI limit value or upper limit weight in-use.	Send a set value.
?LO	Send a LO limit value or lower limit weight in-use.	
OK	Set a target weight.	Set "+" and 6 digit (5 digit for %) number without decimal point.
HI	Set a HI limit value or upper limit weight.	
LO	Set a LO limit value or lower limit weight.	
ML	Store the comparator limits into the specified memory number.	
CM	Clear the contents of specified memory number.	

Examples of command and reply (“_” shows “Space” (20H).)

Examples below are for F20-0 (Reply to command is sent.)

- Request a weight data.

Command

Q	C	L _F
---	---	----------------

Reply

S	T	,	+	0	0	1	2	.	3	4	5	_	k	g	C	L _F
U	S	,	+	0	0	0	7	.	8	9	0	_	k	g	C	L _F
O	L	,	+	9	9	9	9	.	9	9	9	_	k	g	C	L _F

 Stable Positive Data
Unstable Positive Data
'E' display

- Zero the scale. (No reply for F20-1.)

Command

Z	C	L _F
---	---	----------------

Reply

Z	C	L _F
---	---	----------------

 The scale is within the zero range and stable.

- Tare the scale. (No reply for F20-1.)

Command

T	C	L _F
---	---	----------------

Reply

T	C	L _F
---	---	----------------

 The scale shows positive and stable data.

- Switch the weighing unit. (No reply for F20-1.)

Command

U	C	L _F
---	---	----------------

Reply

U	C	L _F
---	---	----------------

 Switch the weighing unit to the next weighing unit.

- Switch the analog sweep display mode. (No reply for F20-1.)

Command

D	C	L _F
---	---	----------------

Reply

D	C	L _F
---	---	----------------

 Switch the display mode to the next display mode.

- ❑ Set a preset tare weight. (No reply for F20-1.)

Command

P	T	,	+	0	0	1	2	0	0	C	L _F
---	---	---	---	---	---	---	---	---	---	---	----------------

 Decimal point follows the weight display.

Reply

P	T	,	+	0	0	1	2	0	0	C	L _F
---	---	---	---	---	---	---	---	---	---	---	----------------

FS-15Ki : The preset tare weight 1.200 kg is subtracted and the display shows net weight.

- ❑ Clear tare weight. (No reply for F20-1.)

Command

C	T	C	L _F
---	---	---	----------------

Reply

C	T	C	L _F
---	---	---	----------------

- ❑ Send a preset tare weight in-use.

Command

?	P	T	C	L _F
---	---	---	---	----------------

Reply

P	T	,	+	0	0	0	1	2	.	0	0	_	k	g	C	L _F
---	---	---	---	---	---	---	---	---	---	---	---	---	---	---	---	----------------

- ❑ Send a tare weight in-use.

Command

?	T	R	C	L _F
---	---	---	---	----------------

Reply

T	R	,	+	0	0	0	1	2	.	0	0	_	k	g	C	L _F
---	---	---	---	---	---	---	---	---	---	---	---	---	---	---	---	----------------

- ❑ Send a target weight in-use.

Command

?	O	K	C	L _F
---	---	---	---	----------------

Reply

O	K	,	+	0	0	0	1	0	.	0	0	_	k	g	C	L _F
---	---	---	---	---	---	---	---	---	---	---	---	---	---	---	---	----------------

- ❑ Send a HI limit value or upper limit weight in-use.

Command

?	H	I	C	L _F
---	---	---	---	----------------

Reply

H	I	,	+	0	0	0	3	.	0	5	0	_	k	g	C	L _F
---	---	---	---	---	---	---	---	---	---	---	---	---	---	---	---	----------------

 Upper limit weight (F07-0)

H	I	,	+	0	0	0	0	.	0	5	0	_	k	g	C	L _F
---	---	---	---	---	---	---	---	---	---	---	---	---	---	---	---	----------------

 HI limit weight (F07-1)

H	I	,	+	0	0	0	0	1	.	0	0	_	_	%	C	L _F
---	---	---	---	---	---	---	---	---	---	---	---	---	---	---	---	----------------

 HI limit % (F07-2)

- ❑ Send a LO limit value or lower limit weight in-use.

Command

?	L	O	C	L _F
---	---	---	---	----------------

Reply

L	O	,	+	0	0	0	2	.	9	5	0	_	k	g	C	L _F
---	---	---	---	---	---	---	---	---	---	---	---	---	---	---	---	----------------

 Lower limit weight (F07-0)

L	O	,	+	0	0	0	0	.	0	3	0	_	k	g	C	L _F
---	---	---	---	---	---	---	---	---	---	---	---	---	---	---	---	----------------

 LO limit weight

L	O	,	+	0	0	0	0	0	.	5	0	_	_	%	C	L _F
---	---	---	---	---	---	---	---	---	---	---	---	---	---	---	---	----------------

 LO limit % (F07-2)

- ❑ Set a target weight. (Use with F07-1 or F07-2. No reply for F20-1.)

Command

O	K	,	+	0	0	1	0	0	0	C	L _F
---	---	---	---	---	---	---	---	---	---	---	----------------

 Decimal point follows the weight display.

Reply

O	K	,	+	0	0	1	0	0	0	C	L _F
---	---	---	---	---	---	---	---	---	---	---	----------------

FS-15K_i : Target weight 1.000 kg will be set.

- ❑ Set a HI limit value or upper limit weight. (No reply for F20-1.)

F07-0 or F07-1 is set, the command should have “+” and 6 digit number without decimal point.

Command

H	I	,	+	0	0	0	2	0	0	C	L _F
---	---	---	---	---	---	---	---	---	---	---	----------------

 Decimal point follows the weight display.

Reply

H	I	,	+	0	0	0	2	0	0	C	L _F
---	---	---	---	---	---	---	---	---	---	---	----------------

FS-15K_i :

F07-0: 0.200 kg will be set as an upper limit weight.

F07-1: 0.200 kg will be set as a HI limit weight.

F07-2 is set, the command should have “+” and 5 digit number without decimal point.

Command

H	I	,	+	0	0	2	0	0	C	L _F
---	---	---	---	---	---	---	---	---	---	----------------

 Assume 2 decimal place number.

Reply

H	I	,	+	0	0	2	0	0	C	L _F
---	---	---	---	---	---	---	---	---	---	----------------

 2.00% will be set as HI limit %.

- ❑ Set a LO limit value or lower limit weight. (No reply for F20-1.)

F07-0 or F07-1 is set, the command should have “+” and 6 digit number without decimal point.

Command

L	O	,	+	0	0	0	1	0	0	C	L _F
---	---	---	---	---	---	---	---	---	---	---	----------------

 Decimal point follows the weight display.

Reply

L	O	,	+	0	0	0	1	0	0	C	L _F
---	---	---	---	---	---	---	---	---	---	---	----------------

FS-15K_i :

F07-0: 0.100 kg will be set as a lower limit weight.

F07-1: 0.100 kg will be set as a LO limit weight.

F07-2 is set, the command should have “+” and 5 digit number without decimal point.

Command

H	I	,	+	0	0	1	0	0	C	L _F
---	---	---	---	---	---	---	---	---	---	----------------

 Assume 2 decimal place number.

Reply

H	I	,	+	0	0	1	0	0	C	L _F
---	---	---	---	---	---	---	---	---	---	----------------

 1.00% will be set as LO limit %.

- ❑ Store the comparator limits into the specified memory number. (No reply for F20-1.)

F07-0 is set, the command should have 2 digit memory number and 2 setting values that have a polarity and 6 digit number without decimal point.

Command

M	L	,	0	1	,	+	0	0	1	2	0	0	,	+	0	0	0	9	0	0	C	L _F
---	---	---	---	---	---	---	---	---	---	---	---	---	---	---	---	---	---	---	---	---	---	----------------

Reply

H	I	,	0	1	,	+	0	0	1	2	0	0	,	+	0	0	0	9	0	0	C	L _F
---	---	---	---	---	---	---	---	---	---	---	---	---	---	---	---	---	---	---	---	---	---	----------------

FS-15K_i : Store upper limit weight +1.200 kg and lower limit weight +0.900 kg into the memory number “01”.

F07-1 is set, the command should have 2 digit memory number, target weight that has a polarity and 6 digit number without decimal point, and HI/LO limit weight that has “+” and 6 digit number without decimal point.

Command

M	L	,	0	1	,	+	0	0	1	0	0	0	,	+	0	0	0	2	0	0	,
+	0	0	0	1	0	0	C	L _F													

Reply

M	L	,	0	1	,	+	0	0	1	0	0	0	,	+	0	0	0	2	0	0	,
+	0	0	0	1	0	0	C	L _F													

FS-15Ki : Store target weight 1.000 kg, upper limit weight +0.200 kg and lower limit weight +0.100 kg into the memory number “01”.

F07-2 is set, the command should have 2 digit memory number, target weight that has a polarity and 6 digit number without decimal point, and HI/LO limit % that has “+” and 5 digit number without decimal point.

Command

M	L	,	0	1	,	+	0	0	1	0	0	0	,	+	0	0	0	2	0	,
+	0	0	0	1	0	C	L _F													

Reply

M	L	,	0	1	,	+	0	0	1	0	0	0	,	+	0	0	0	2	0	,
+	0	0	0	1	0	C	L _F													

FS-15Ki : Store target weight 1.000 kg, upper limit +0.2 % and lower limit +0.1 % into the memory number “01”.

- Clear the contents of specified memory number. (No reply for F20-1.)

Command

C	M	,	0	1	C	L _F
---	---	---	---	---	---	----------------

 Clear the contents of memory number “01”.

Reply

C	M	,	0	1	C	L _F
---	---	---	---	---	---	----------------

Reply in case of the function setting F20-0

There are other replies to the commands other than examples above, when the function setting F20-0 is selected.

- The scale is not in a state where a command could be executed. Then, the scale will reply “I”.

Command

Z	C	L _F
---	---	----------------

Reply

I	C	L _F
---	---	----------------

 The scale is not within the zero range or unstable.

- Command does not exist for the scale. Then, the scale will reply “?”.

Command

B	C	L _F
---	---	----------------

 Undefined command for the scale.

Reply

?	C	L _F
---	---	----------------

- When the function setting F20-1 is selected, there is no reply to those commands.

2-4. Using UFC (Universal Flex Coms) function

- The UFC function allows you to format the print out (UFC format).
- The scale can store the UFC format as text data. It will include parameters to replace with the weight data, tare data and so on.

- The maximum number of text data is 300 characters.
- To use the UFC function, the text data has to be sent to the scale from the computer using “PF” command in the command mode (F06-1) in advance. Then, connect the scale with the printer and set the F06-2, F06-3 or F06-4.**
- When the PRINT key is pressed or by auto-print mode (F06-2, F06-3 or F06-4), the scale will send the stored text data with the parameters replaced by the original data.

Store Text Data into the Scale Memory

Command	P	F	,	\$	P	C	,	‘	T	E	X	T	’	,	#	2	0	,	\$	S	P	*	2	,	&
	\$	C	R	,	\$	L	F	,	\$	W	T	,	\$	C	R	,	\$	L	F	C	L _F				
Reply	P	F	C	L _F																					

The “PF” command sends text data that will include:

- Parameters for the scale data and control codes.

Parameter	Data & Code	Parameter	Data & Code
\$WT	Weight	\$CM	Comma (2CH)
\$TR	Tare weight in use	\$SP	Space (20H)
\$CP	Comparator result	\$CR	C _R (0DH)
\$OK	Target weight	\$LF	L _F (0AH)
\$HI	HI limit value or upper limit weight	\$LO	LO limit value or lower limit weight

- These parameters must be used in capital letters.
- ASCII text string

A text string is described in single quote marks as ‘Data’. The single quote itself is written as ’(2 single quotes).

Example: Text ABC is described as ‘ABC’.

 Text ‘ABC’ is described as ’’ABC’’.
- The ASCII hexadecimal code

The ASCII hexadecimal codes are written in the form “#” + 2 hexadecimal digits. This will mainly be used to send control codes that can’t be described as a text string.

Example: #04 “EOT” of ASCII code
- Repeat data

The control codes \$SP, \$CR and \$LF can be used with “* plus a 1 or 2 digit number”. That code will be repeated the number of times designated.

Example: \$LF*9 Repeat “\$LF” 9 times.

 \$SP*12 Use 12 “Spaces”.
- Link mark “&”

If you will send more than 2 lines of data, attach "&" to the end of the first line. Then, the scale considers the data to be continued.

□ A "Space" or "," will be used to separate these data. You can skip them to reduce the number of characters, but you cannot skip "," after "PF". You must start with "PF,".

Data Format for the Scale Data ("_" shows "Space" (20H).)

Parameters for the scale data will be replaced by the format below when the scale sends them out.

□ Data has a fixed number of digits including a sign and a decimal point. The insignificant zeros are replaced by "Space (20H)".

\$WT	<table border="1" style="display: inline-table; border-collapse: collapse;"><tr><td>_</td><td>_</td><td>_</td><td>+</td><td>1</td><td>.</td><td>2</td><td>3</td><td>4</td><td>_</td><td>k</td><td>g</td></tr></table>	_	_	_	+	1	.	2	3	4	_	k	g	1.234 kg / 9 digit weight data + 3 digit unit
_	_	_	+	1	.	2	3	4	_	k	g			
\$TR	<table border="1" style="display: inline-table; border-collapse: collapse;"><tr><td>_</td><td>_</td><td>_</td><td>+</td><td>1</td><td>.</td><td>2</td><td>3</td><td>4</td><td>_</td><td>k</td><td>g</td></tr></table>	_	_	_	+	1	.	2	3	4	_	k	g	1.234 kg / 9 digit tare data + 3 digit unit
_	_	_	+	1	.	2	3	4	_	k	g			
\$CP	<table border="1" style="display: inline-table; border-collapse: collapse;"><tr><td>O</td><td>K</td></tr></table>	O	K	Comparator result "OK" / 2 characters										
	O	K												
	<table border="1" style="display: inline-table; border-collapse: collapse;"><tr><td>H</td><td>I</td></tr></table>	H	I	Comparator result "HI" / 2 characters										
	H	I												
<table border="1" style="display: inline-table; border-collapse: collapse;"><tr><td>L</td><td>O</td></tr></table>	L	O	Comparator result "LO" / 2 characters											
L	O													
<table border="1" style="display: inline-table; border-collapse: collapse;"><tr><td>_</td><td>_</td></tr></table>	_	_	No Comparator result / 2 spaces											
_	_													
\$OK	<table border="1" style="display: inline-table; border-collapse: collapse;"><tr><td>_</td><td>_</td><td>_</td><td>+</td><td>1</td><td>.</td><td>0</td><td>0</td><td>0</td><td>_</td><td>k</td><td>g</td></tr></table>	_	_	_	+	1	.	0	0	0	_	k	g	1.000 kg / 9 digit target data + 3 digit unit
_	_	_	+	1	.	0	0	0	_	k	g			
\$HI	<table border="1" style="display: inline-table; border-collapse: collapse;"><tr><td>_</td><td>_</td><td>_</td><td>+</td><td>0</td><td>.</td><td>2</td><td>0</td><td>0</td><td>_</td><td>k</td><td>g</td></tr></table>	_	_	_	+	0	.	2	0	0	_	k	g	0.200 kg / 9 digit HI data + 3 digit unit
_	_	_	+	0	.	2	0	0	_	k	g			
\$LO	<table border="1" style="display: inline-table; border-collapse: collapse;"><tr><td>_</td><td>_</td><td>_</td><td>+</td><td>0</td><td>1</td><td>.</td><td>0</td><td>0</td><td>_</td><td>_</td><td>%</td></tr></table>	_	_	_	+	0	1	.	0	0	_	_	%	1.00 % / 9 digit LO data + 3 digit unit
_	_	_	+	0	1	.	0	0	_	_	%			

Examples of PF command and AD-8121B Printout Sample

AD-8121B
(FS-i → AD-8121B)

```

Weight
          +1.234 kg
CHECK
          OK

DATE 09/18/2006
TIME 12:34:56

A&D FS-15Ki
```

"PF" Command
(Computer → FS-i)

```
PF, 'weight', $CR, $LF, &
$SP*4, $WT, $CR, $LF, &
'CHECK', $CR, $LF, &
$SP*7, $CP, $CR, $LF, &
$CR, $LF, &
#1B, #44, $CR, $LF, &
#1B, #54, $CR, $LF, &
$CR, $LF, &
'_A&D_FS-15Ki', $CR, $LF
```

Terminator code

"_" shows "Space".

□ Normally the printer needs to receive the terminator, and do not forget to add the terminator code to the end of text data.

3. OP-04 RS-422 / 485 / RELAY OUTPUT

This interface allows a personal computer to connect and control up to 16 FS-*i* scales, and the relay outputs for comparator result are obtained.

- ❑ The OP-04 unit includes an interface board, a connector cable, two cable glands and two screws (M3x6).
- ❑ The relay output specifications are same as the OP-03. See “2-2. OP-03 Specifications”.

3-1. Installation

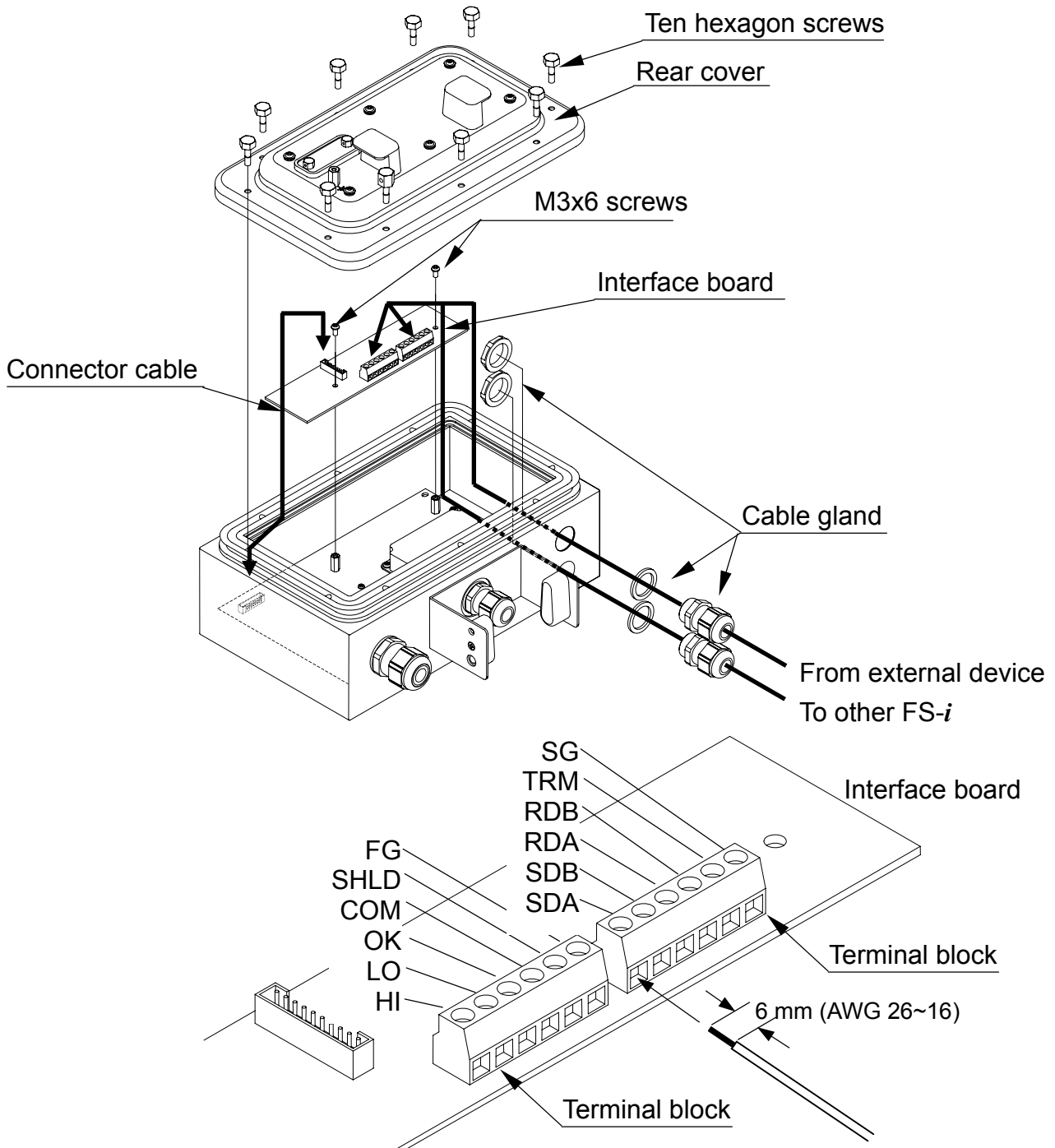

- ❑ Installation is similar to the OP-03. See “2-1. Installation”.
- ❑ Set the function parameters F04, F05, F06, F18, F19 and F20 according your application.
- ❑ *The function setting F19-1 must be set for RS-422 and F19-2 must be RS-485. To connect more than one scale with a computer, set a different address to each scale by F18-##.*

3-2. OP-04 Specifications

RS-422/485 Specifications

Transmission form	Asynchronous, bi-directional, half-duplex
Data format	Baud rate: 2400, 4800, 9600 bps
(non-parity)	Data: 7 bits + parity 1bit (even / odd) or 8 bits
	Start bit: 1 bit
	Stop bit: 1 bit
	Code: ASCII
	Terminator: C _R L _F

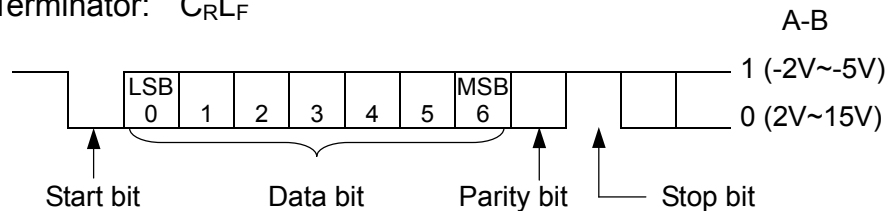

Circuit diagram

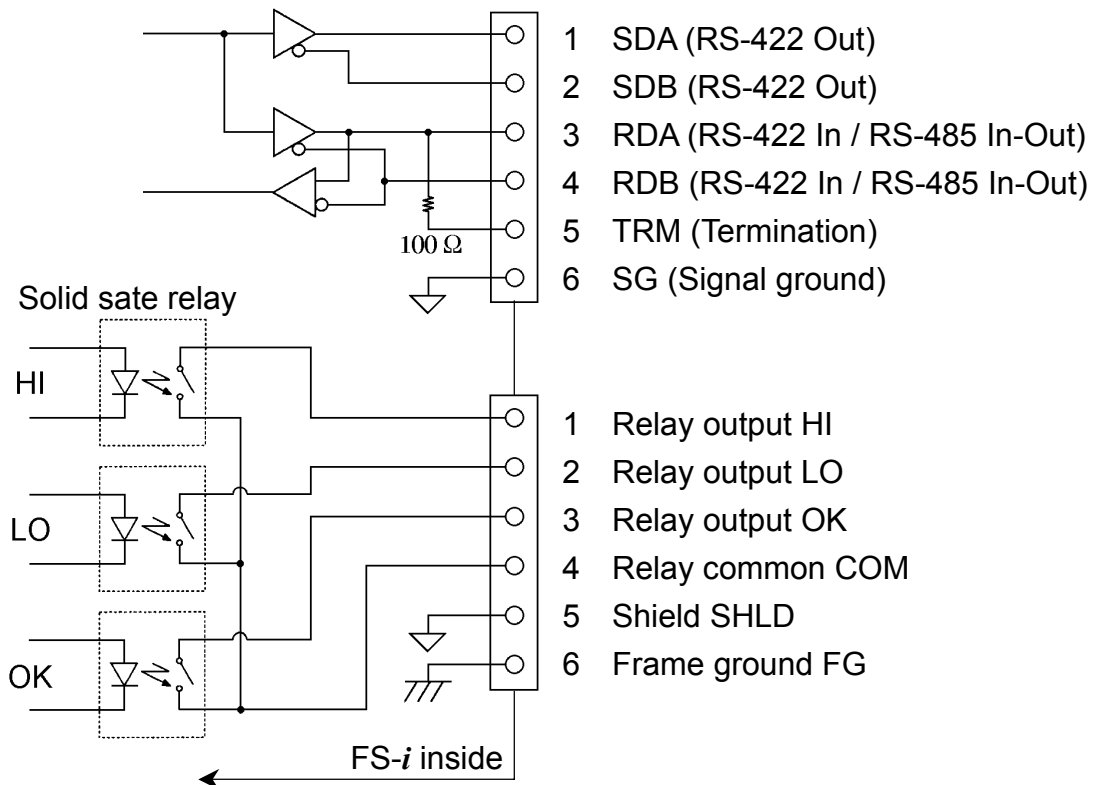

Example of connection

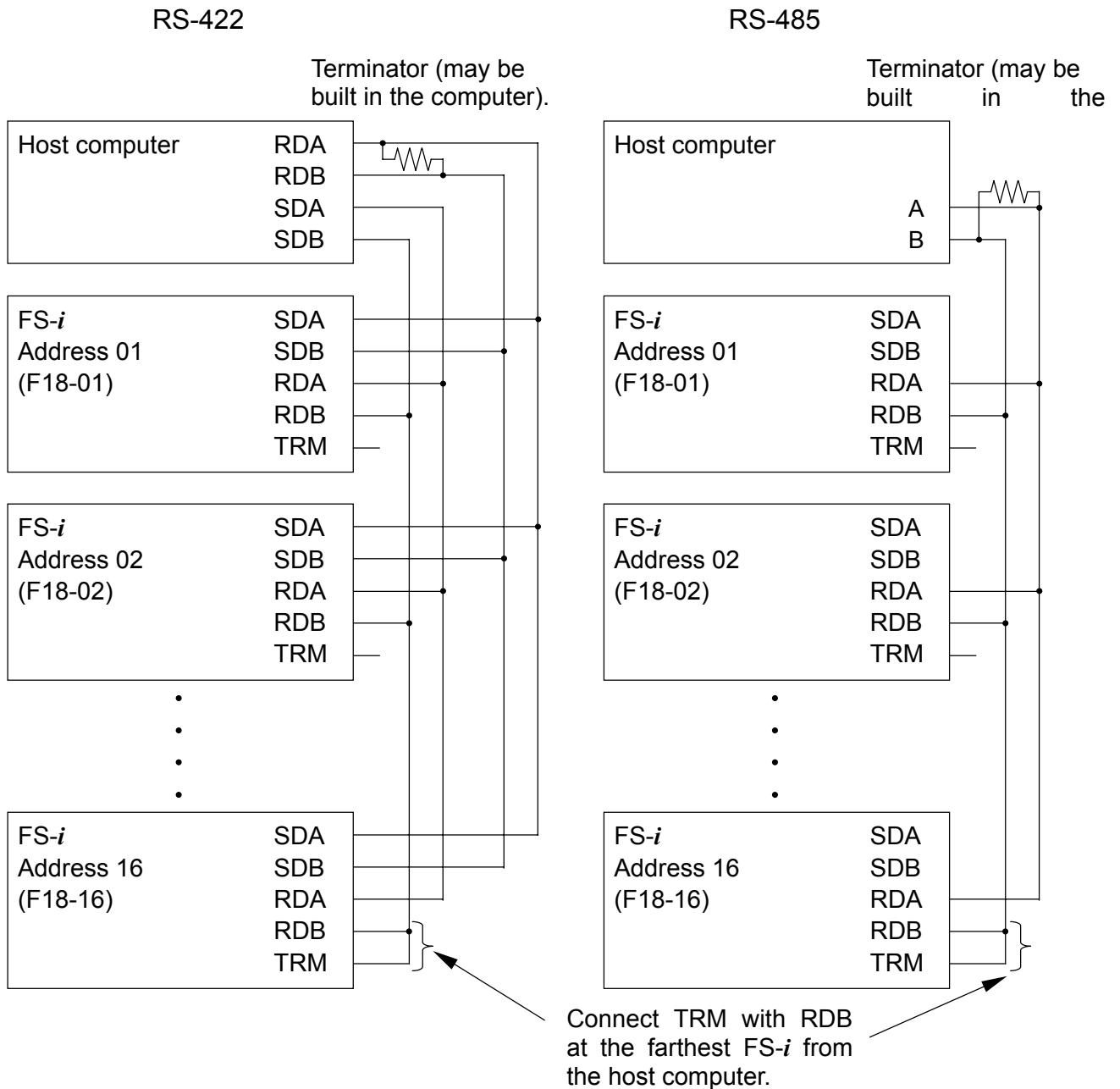

- The polarity (A, B) of the host computer signal depends on model. Check the technical manual of the computer.

3-3. Data output

Data and commands for the RS-422/485 are same as the RS-232C except following.

- When used with the setting F19-1 (RS-422) or F1-2 (RS-485), set a different address F18-## (## = 01 ~ 99) to each scale.
- Add "@##" (## is the address of the scale to send a command) at the head of command of the RS-232C. All of data or reply from the scale have "@##" at the head.

Examples of command and reply (“_” shows “Space” (20H).)

Following examples are for F20-0 (Reply to command is sent.)

The address ## = 23 (F18-23).

- Request a weight data.

Command

@	2	3	Q	C	L _F
---	---	---	---	---	----------------

Reply

@	2	3	S	T	,	+	0	0	1	2	.	3	4	5	_	k	g	C	L _F	Stable data
@	2	3	U	S	,	+	0	0	0	7	.	8	9	0	_	k	g	C	L _F	Unstable data
@	2	3	O	L	,	+	9	9	9	9	.	9	9	9	_	k	g	C	L _F	“E” display

- Zero the scale. (No reply for F20-1.)

Command

@	2	3	Z	C	L _F
---	---	---	---	---	----------------

Reply

@	2	3	Z	C	L _F
---	---	---	---	---	----------------

 The scale is within the zero range and stable.

- Send a target weight in-use.

Command

@	2	3	?	O	K	C	L _F
---	---	---	---	---	---	---	----------------

Reply

@	2	3	O	K	,	+	0	0	0	1	0	.	0	0	_	k	g	C	L _F
---	---	---	---	---	---	---	---	---	---	---	---	---	---	---	---	---	---	---	----------------



A&D Company, Limited

3-23-14 Higashi-Ikebukuro, Toshima-ku, Tokyo 170-0013 JAPAN
Telephone: [81] (3) 5391-6132 Fax: [81] (3) 5391-6148

A&D ENGINEERING, INC.

1555, McCandless Drive, Milpitas, CA. 95035 U.S.A.
Telephone: [1] (408) 263-5333 Fax: [1] (408) 263-0119

A&D INSTRUMENTS LTD.

Unit 24/26 Blacklands Way, Abingdon Business Park, Abingdon, Oxon OX14 1DY United Kingdom
Telephone: [44] (1235) 550420 Fax: [44] (1235) 550485

<German Scales Office>

Große Straße 13 b 22926 Ahrensburg GERMANY
Telephone: [49] (0) 4102 459230 Fax: [49] (0) 4102 459231

A&D MERCURY PTY. LTD.

32 Dew Street, Thebarton, South Australia 5031 AUSTRALIA
Telephone: [61] (8) 8301-8100 Fax: [61] (8) 8352-7409

A&D KOREA Limited

8th Floor, Manhattan Bldg. 36-2 Yoido-dong, Youngdeungpo-ku, Seoul, KOREA
Telephone: [82] (2) 780-4101 Fax: [82] (2) 782-4280