

# AD-8551R

## Modbus RTU Converter

### INSTRUCTION MANUAL



---



A&D Company, Ltd.

# This manual and Marks

All safety messages are identified by the following, "WARNING" or "CAUTION", of ANSI Z535.4 (American National Standard Institute: Product Safety Signs and Labels). The meanings are as follows:

 <b>WARNING</b>	A potentially hazardous situation which, if not avoided, could result in death or serious injury.
 <b>CAUTION</b>	A potentially hazardous situation which, if not avoided, may result in minor or moderate injury.



This is a hazard alert mark.

- This manual is subject to change without notice, at any time, to improve the product.
- The contents of the product specifications and this manual are subject to change without any obligation on the part of the manufacturer.
- Under the copyright laws, the software (program) described in this manual is copyrighted, with all rights reserved.  
The software may be installed into one computer and may not be installed into other computers without the prior written consent of A&D Company, Limited. Copying includes translation into another language, reproduction, conversion, photocopy and offer or loan to another person.

© 2019 **A&D Company, Limited** All rights reserved.

No part of this publication may be reproduced, transmitted, transcribed, or translated into any language in any form by any means without the written permission of A&D Company, Limited.

# Contents

1. Introduction .....	2
1-1 Features .....	2
1-2 Cautions .....	3
2. Composition and Names .....	4
2-1 AD-8551R .....	4
2-2 Accessories .....	4
3. Specifications .....	5
3-1 Dimensions .....	5
3-2 Applicable models .....	6
4. Power Terminal .....	7
4-1 Power-supply voltage .....	7
4-2 Connecting example .....	8
4-3 Internal connection status .....	8
5. RS-485 Interface .....	9
5-1 RS-485 specifications .....	9
5-2 Connections .....	10
6. RS-232C Interface .....	11
6-1 RS-232C specifications .....	11
6-2 Connecting cable .....	11
7. Switch .....	12
7-1 How to operate the switch .....	12
7-2 Factory setting .....	12
7-3 RS-485 function settings .....	13
7-4 RS-232C function settings .....	15
7-5 Fixed decimal point function .....	16
8. LED (status, error display) .....	17
9. Communication in Modbus RTU Mode .....	18
9-1 Preparing for communication .....	19
9-2 Data address .....	20
9-3 Detailed information on Holding Register 1 .....	21
9-4 Detailed information on Holding Register 2 (only for AD-4212C/AD-4212D) .....	22
9-5 Communication format .....	23
9-6 Operating example (When connected to the AD-4212C/AD-4212D) .....	25
10. Communication in Command Mode .....	27
10-1 Preparing for communication .....	27
10-2 Communication format .....	28
11. Troubleshooting .....	29
11-1 Modbus RTU mode communication check .....	29
11-2 Command mode communication check .....	30

# 1. Introduction

Thank you for purchasing the AD-8551R Modbus RTU convertor.

Please read this manual completely before using the AD-8551R.

## 1-1 Features

The AD-8551R converts the RS-232C communications of the weighing device into RS-485 (Modbus RTU) communications (RS-232C/RS-485 converter). Use of the RS-485 enables the collection of data control of up to 31 weighing devices (addresses ranging from 1 to 63) by a single PLC.

- The RS-485 communication method of the AD-8551R can be used by selecting either Modbus RTU communication (Modbus RTU mode) or ASCII code command communication (command mode).
- The measurement value can be reset to zero (re-zero) by operation from the PLC or PC.
- When connected to an AD-4212C and AD-4212D, etc., it is possible to change the response speed, perform calibration with an external weight, and supply power from the weighing device.
- The hooks on the back of the AD-8551R allow one-touch mounting on a DIN rail.

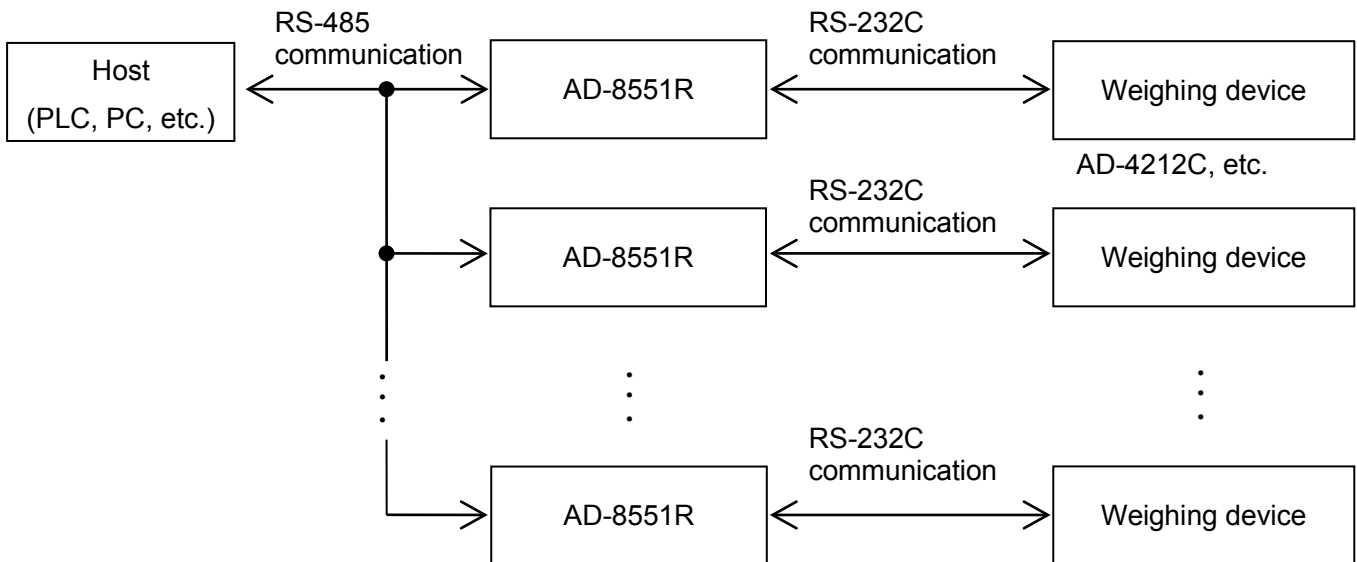

## 1-2 Cautions

Before use, confirm the following articles for safe operation.

### □ Grounding The Convertor

Be sure to ground this convertor. (For the internal connection status of AD-8551R, refer to “4-3 Internal connection status”).

Separate this earth ground line from others, like ground line of a motor, inverter or a power source. Unless the convertor is grounded, it may result in receiving an electric shock, cause operation error or catch fire.

### □ Proper Power Source And Power Cable

Confirm the AC voltage, frequency and power tolerance of the power cable (refer to “4. Power Terminal”). If the voltage range of the cable is lower than the power line voltage, it may cause leakage or catching fire. Use pole compression terminals to connect the power cable to the terminals.

### □ Splashing Water

The module is not water-resistant type.

### □ Flammable Gas

Do not install the convertor where flammable gas is present.

### □ Heat Radiation Of The Module

Space out instruments to radiate heat sufficiently.

Do not use in an environment where the ambient temperature exceeds the operating temperature range [-10°C to +50°C, 85% RH or less (no condensation)].

This unit is covered with a transparent plastic protective cover at the time of shipment.

After installing and connecting, be sure to remove the protective cover before turning on the power.

If it is used without removing the protective cover, this unit will overheat.

The protective cover is for preventing the entry of wire scraps and the like during installation and connecting.

Do not remove it until installation and connecting are complete.

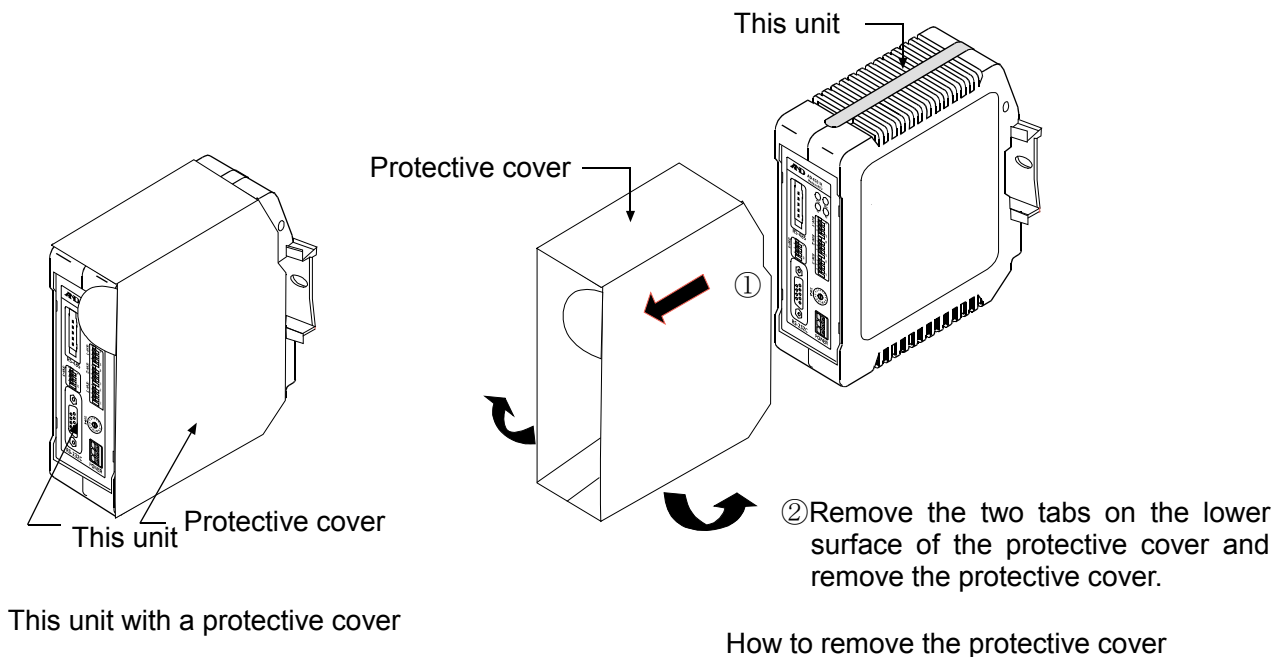

## 2. Composition and Names

### 2-1 AD-8551R

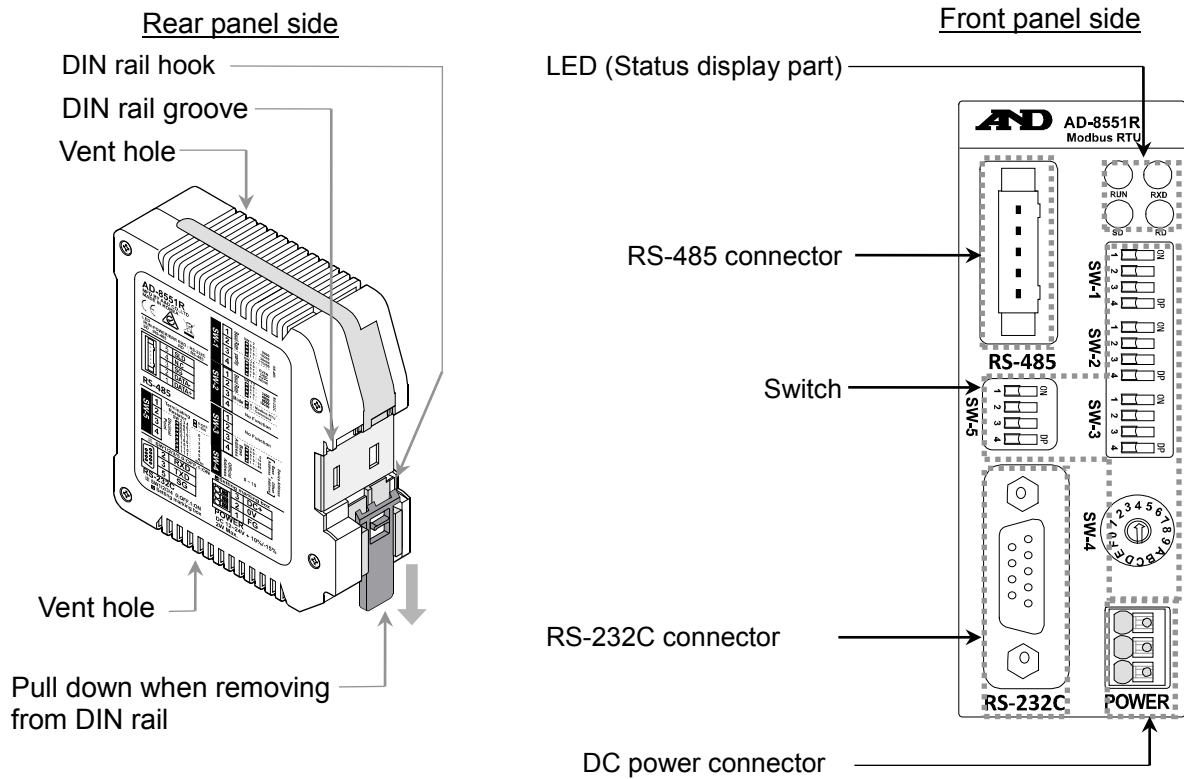

#### DIN rail mounting example

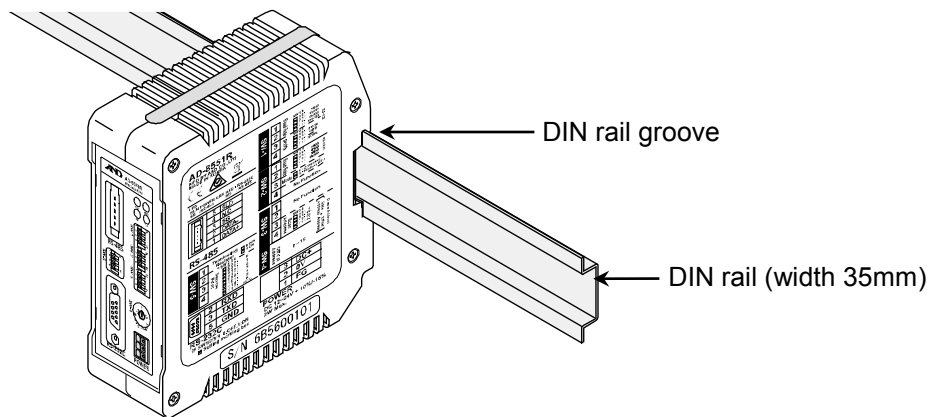

### 2-2 Accessories

- Simplified instruction manual
- RS-485 connector (power clamp wire mount socket)  
Model : AX-35505-6200-A (Made by 3M 35505-6200-A00 GF)

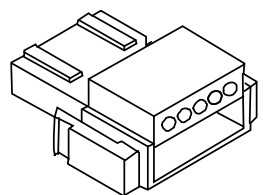

# 3. Specifications

Voltage requirement : 12 to 24 VDC [+ 10%, -15%]

Power requirement : 2W Max

Communication interface : RS-485 (Modbus RTU or command for connection to control equipment)

Refer to "5-1 RS-485 specifications"

: RS-232C interface (For connection to weighing device)

Refer to "6-1 RS-232C specifications"

Communication connector : 5 pin (male) : Made by 3M 35605-5153-A00 (For RS-485 interface)

D-Sub 9 pin (male) (For RS-232C interface)

Operating condition : -10°C to + 50°C, Max 85% RH (no condensation)

External dimensions : 35 (W) x 110 (H) x 101 (D)

Mass : Approximately 170g

Accessory : RS-485 connector (power clamp wire mount socket) 1 piece

## 3-1 Dimensions

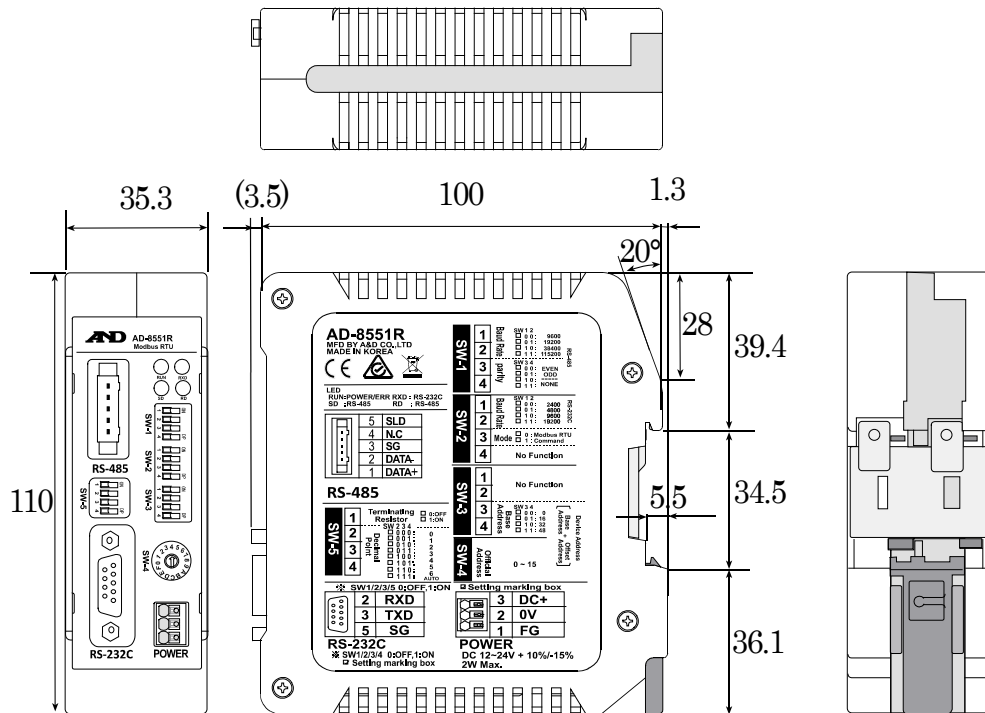

Unit : mm

## 3-2 Applicable models

■ Functions available for each model, accessories needed for connection to AD8551R.

		Accessories needed to connect the AD8551R to a weighing device		Modbus RTU												Command mode *1	Convenient functions		
		Weighing device output options	Cable needed for connection between weighing device and AD8551R	Data that can be read from the host					Operations that can be made from the host								Power supply from the weighing device	Auto power on function*2	
				Weighing value	Status information	Response speed	Calibration status	Calibration weight value	Re-zero	Zero	Taring	Calibration with internal weight	Calibration with your own weight	Changing the display digit	Changing the response speed				Changing the unit
AD4212C		Unnecessary	Cable included with the weighing device	○	○	○	○	○	○	×	×	×	○	○	○	×	○*3	○	○
AD4212D	*6 Connector for A&D's external display	Unnecessary	Cable included with the weighing device	○	○	○	○	○	○	×	×	○	○	○	○	×	○	○	○
	Connector for the PC/PLC	Unnecessary	AX-KO4472-1000	△	△	△	△	△	△	△	△	△	△	△	△	△	○	×	○
AD4212A/B		Unnecessary	AX-KO1710-200	○	△*4	×	×	×	○	×	×	×	×	○	×	×	○	×	○
GX-A		Unnecessary	AX-KO2466-200	○	△*4	×	×	×	○	○	○	○	×	○	×	○	○	○	○
GF-A		Unnecessary	AX-KO2466-200	○	△*4	×	×	×	○	○	○	×	×	○	×	○	○	○	○
FZi, HR-AZ		Unnecessary	AX-KO2466-200	○	△*4	×	×	×	○	×	×	○	×	○	×	○	○	○	○
FXi, HR-A		Unnecessary	AX-KO2466-200	○	△*4	×	×	×	○	×	×	×	×	○	×	○	○	○	○
GX, GX-K, GP		Unnecessary	AX-KO1710-200	○	△*4	×	×	×	○	×	×	○	×	○	×	○	○	×	○
GF, GF-K, GP		Unnecessary	AX-KO1710-200	○	△*4	×	×	×	○	×	×	×	×	○	×	○	○	×	○
BM, GH		Unnecessary	AX-KO2466-200	○	△*4	×	×	×	○	×	×	○	×	○	×	○	○	×	○
HR-i		Unnecessary	AX-KO2466-200	○	△*4	×	×	×	○	×	×	×	×	○	×	○	○	×	○
GR		Unnecessary	AX-KO1710-200	○	△*4	×	×	×	○	×	×	○	×	×	×	○	○	×	○
HR		HR-03 (Included with weighing device)	AX-KO1710-200	○	△*4	×	×	×	○	×	×	×	×	○	×	○	○	×	○
FC-i		Unnecessary	AX-KO2466-200	○	△*4	×	×	×	×	×	×	×	×	×	×	×	○	×	×
HC-i		HC-03i	AX-KO1786-200	○	△*4	×	×	×	×	○	○	×	×	×	×	×	○	×	×
Eki, Ewi		Unnecessary	AX-KO2466-200	○	△*4	×	×	×	○	×	×	×	×	×	×	○	○	×	×
EJ, EJ-B		EJ-03	AX-KO2466-200	○	△*4	×	×	×	○	×	×	×	×	×	×	○	○	×	×
EK-L		Unnecessary	AX-KO2466-200	○	△*4	×	×	×	○	×	×	×	×	×	×	○	○	△*5	×
HV-CWP		HVW-03CWP	AX-KO3285-320	○	△*4	×	×	×	×	○	○	×	×	×	×	○	○	×	○
HV-C, HV-CP, HW-C, HW-CP		HVW-03C	AX-KO2466-200	○	△*4	×	×	×	×	○	○	×	×	×	○	○	○	×	○
HV-G, HW-G, HW-WP		Unnecessary	AX-KO1786-200	○	△*4	×	×	×	×	○	○	×	×	×	○	○	○	×	×
FG		FG-23 / FG-24	AX-KO1786-200	○	△*4	×	×	×	×	○	○	×	×	×	×	○	○	×	×
FS-i		FS-03i	AX-KO3285-320	○	△*4	×	×	×	×	○	○	×	×	×	○	○	○	×	×
SC/SE		SCE-03	AX-KO3285-320	○	△*4	×	×	×	○	×	×	×	×	×	×	○	○	×	×
SW		SW-03	AX-KO3285-320	○	△*4	×	×	×	×	○	○	×	×	×	○	○	○	×	×

\* 1 . When transferring a large amount of data from a weighing device all at once (GLP output, batch output of data memory, etc.), data may be lost.

\* 2 . If the weighing device does not have an auto power-on function or auto-start function, it is necessary to turn on the display or each weighing device by key operation after turning on the power.

\* 3 . When using the AD4212C in command mode, it is necessary to change to internal settings in advance to enter key mode.

Also, control characters beginning with "@" output from the AD4212C are not output from the AD8551R to the RS-485 side.

\* 4 . Some functions (calibration error flag) cannot be used.

\* 5 . Power can be supplied from the weighing device when the adapter is connected to the weighing device.

\* 6 . The AD4212D has two types of RS-232C connectors. When using in Modbus RTU mode, connect the connector for A&D's external display, and when using in command mode, connect the connector for PC/PLC and RS-232C connector of the AD8551R.

# 4. Power Terminal

When connected to the AD-4212C / AD-4212D, power can be supplied from the weighing instrument (RS-232C connector). No power connecting is required (Refer to “6. RS-232C Interface”).

## 4-1 Power-supply voltage

Connect a constant voltage of external power supply (+ 10% -15%) within the range of 12 to 24 VDC to the DC power input terminal.

### Caution

- Do not use at a voltage exceeding the rated voltage range (12 to 24 VDC +10%-15%)
    - Doing so may cause failure or heat generation.
    - This unit may not operate normally.
  - Ground the FG terminal of the switching power supply used for the power supply of this unit.
- 
- The power line of this unit should be dedicated for this unit, and be separate from other drive devices.
    - If strong noise is generated from the power line of another device, this unit may be damaged.
    - This unit may not start normally due to the inrush current of other drive devices.
    - Depending on the circuit configuration of this unit, other drive devices may not operate normally.
  - Select a switching power supply capacity of approximately 2W per unit for the dedicated power supply line for this unit.
    - If the power capacity is insufficient, this unit may not operate normally.

■ Connector : DC power input terminal

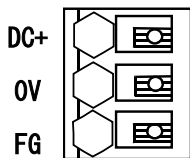

Signal name	Description
DC+	Power supply 12 to 24V input
0V	Power supply 0V input
FG	Frame ground

## 4-2 Connecting example

To insert or remove the wire, press the button part of the connector with a screwdriver or the like.

Modifying the tip of the wire with a bar-type crimp terminal or the like recommended.



Connection conductor specifications

Clamping range (rating)		0.20 mm <sup>2</sup> to 1.5 mm <sup>2</sup>
Applicable wire	AWG	AWG24 to AWG16
	Solder plated wire	0.2 mm <sup>2</sup> to 1.5 mm <sup>2</sup>
	Stranded wire	0.2 mm <sup>2</sup> to 1.5 mm <sup>2</sup>
	Bar crimp terminal DIN 46228 Part 1	0.25 mm <sup>2</sup> to 1.5 mm <sup>2</sup>
	Bar crimp terminal (With color) DIN 46228 Part 4	0.25 mm <sup>2</sup> to 0.75 mm <sup>2</sup>
Length		8 mm

## 4-3 Internal connection status

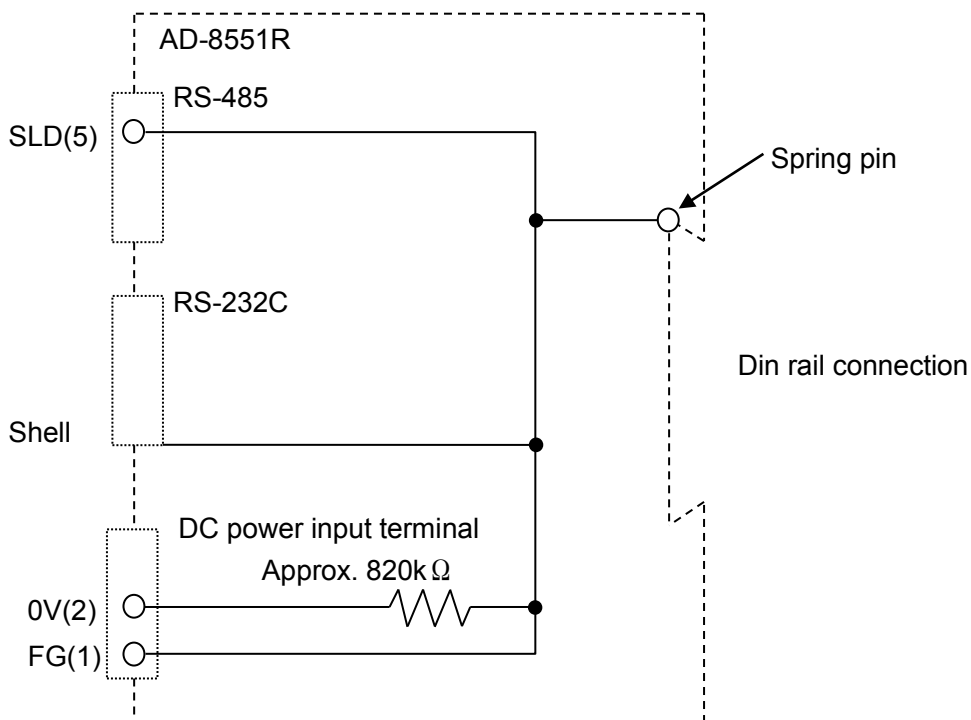

# 5. RS-485 Interface

## 5-1 RS-485 specifications

■ Connector (Made by 3M 35605-5153-A00)

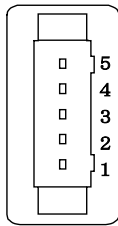

5	SLD	-	Shield *1
4	-	-	N.C
3	SG	-	Signal ground
2	DATA-	Input/Output	Send / Receive data
1	DATA+	Input/Output	Send / Receive data

\* 1 . Connect the shield of the RS-485 cable.

The shield terminal is connected to the DC power input terminal FG, RS-232C connector shell, and DIN rail connection spring connector.

(Refer to “4-3 Internal connection status”)

■ Communication specifications

Item	Communication method [SW-2 No.3]	
	Modbus RTU mode	Command mode
Baud rate [SW-1 No.1, 2]	9600*, 19200, 38400, 115200bps	
Data bit	8 bit (fixed)	
Parity [SW-1 No.3, 4]	EVEN*, ODD, NONE	
Stop bit	1 bit (fixed)	
Terminator	A silent interval of at least 3.5 character times	<CR><LF> (fixed)
Terminating resistor [SW-5 No.1]	Built-in : Yes (100Ω) / No * selected by switch	
Device address setting [SW-3 No.3, 4, SW-4]	01* to 63	
Code	Modbus RTU*	ASCII code commands

\*Factory setting

## 5-2 Connections

### ■ How to connect

- ① RS-485 connector (power clamp wire mount socket)      ③ Branching connector

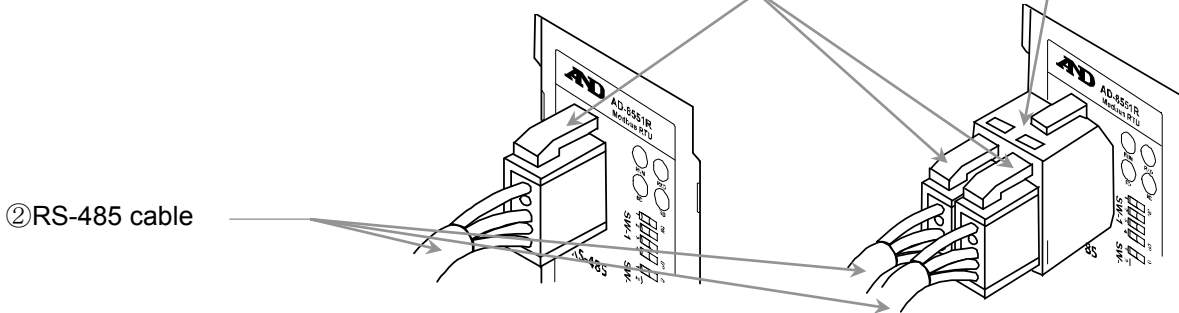

Single connection

Multi drop connection

Item	Description	Accessory
① RS-485 connector (power clamp wire mount socket)	Model: AX-35505-6200-A (Made by 3M 35505-6200-A00)	○ (1 piece)
② RS-485 cable	Recommended specification <ul style="list-style-type: none"> <li>• Twisted pair cable with shield</li> <li>• Wire conductor size AWG#20 (0.50mm<sup>2</sup>)</li> <li>• Characteristic impedance 100 Ω</li> </ul>	×
③ Branching connector	Model: AX-35715-A (Made by 3M 35715-L010-A00) * For multi drop connection. RS-485 connector (power clamp wire mount socket) also needs to be purchased additionally.	×

### ■ Connecting method of cable and connector

- ① Connect the two signal lines (DATA+, DATA-) in twisted pairs and wire the shield of RS-485 to the SLD terminal.  
If the host device does not have a signal ground, the SG terminal connecting is not necessary.
- ② Insert the lead wire all the way in to the cover (yellow portion) without peeling off the cover of the lead wire.
- ③ Push the cover into the body and fix it.
- ④ Make sure that the cover is level with the body and that there is no gap between the body and the cover.

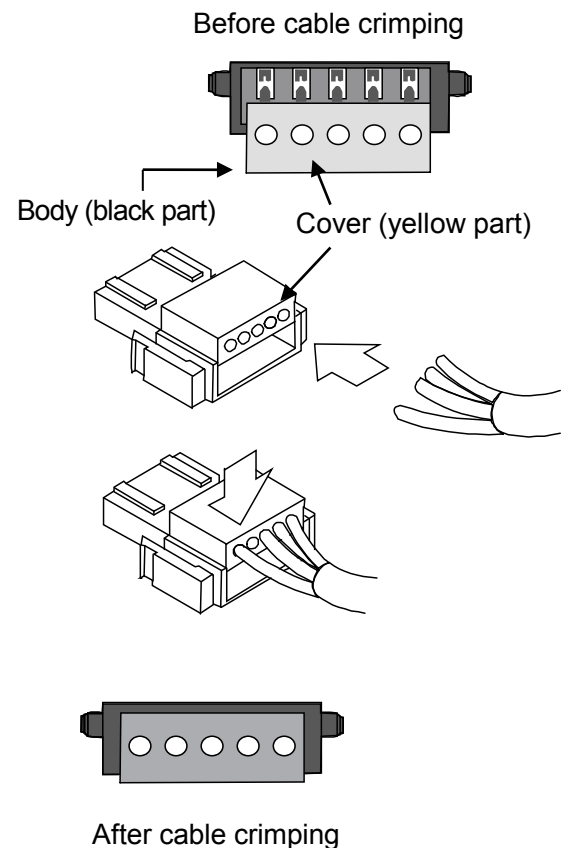

# 6. RS-232C Interface

## 6-1 RS-232C specifications

■ Connector (D-Sub 9 pin, male)

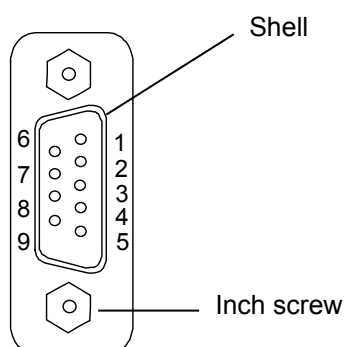

Pin No.	Signal	Direction	Description
1	(Vs)	Input	Input of power supply 0V <sup>*1</sup>
2	RXD	Input	Received data
3	TXD	Output	Transmission data
4	-	-	N.C.
5	SG	-	Signal ground
6	-	-	N.C.
7	-	-	N.C.
8	-	-	N.C.
9	(Va)	Input	Input of power supply 12V <sup>*1</sup>
Shell	-	-	Shield

\* 1 . When connected to the AD-4212C / AD-4212, the AD-8551R can be operated by supplying power from the weighing device.

■ Communication specifications

Item	Setting
Baud rate	[SW-1 No.1, 2] 2400*, 4800, 9600, 19200bps
Data bit	7 bit (fixed)
Parity	EVEN (fixed)
Stop bit	1 bit (fixed)
Terminator	<CR><LF> (fixed)
Code	ASCII

\*Factory setting

## 6-2 Connecting cable

Connect with a cable applicable to the individual weighing device. Refer to “3-2. Applicable models”

■ Connection diagram (When connected to a weighing device.)

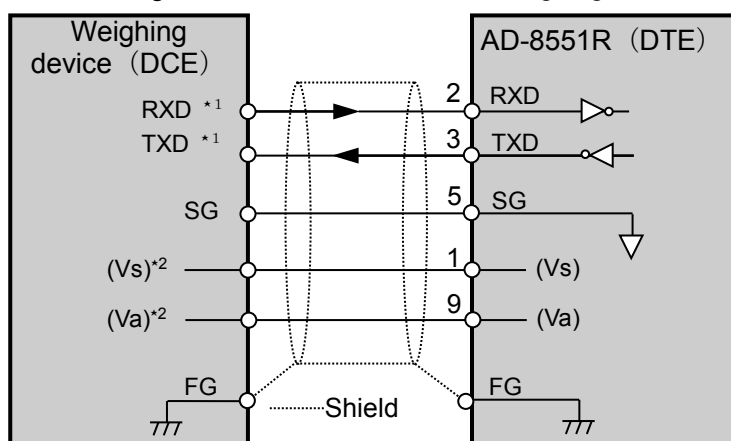

\* 1 . Depending on the weighing device, RXD and TXD may be shown on the opposite side (weighing device output: TXD, weighing device input: RXD)

\* 2 . May vary depending on the weighing device.

# 7. Switch

- Set the parameters required for communication using the AD-8551R switches (SW-1 to 5).

## Caution

- If the setting is changed, be sure to turn on the power off and on again of AD-8551R. When the power is turned on, the switch status is read and applied to operations

## 7-1 How to operate the switch

SW-1 to 3, 5

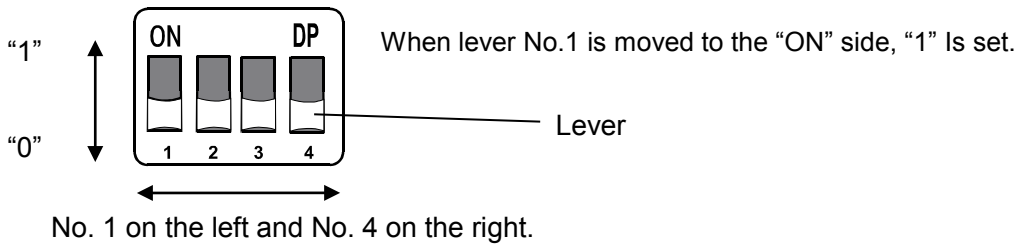

SW-4

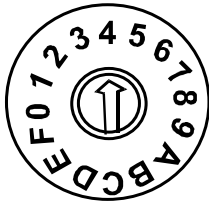

Turn the center arrow to set.  
It can be set from 0 to F.

## 7-2 Factory setting

The switch status and settings at the factory setting are as follows. Refer to "7-3. RS-485 function settings" "7-4. RS-232C function settings" for the settings that need to be changed.

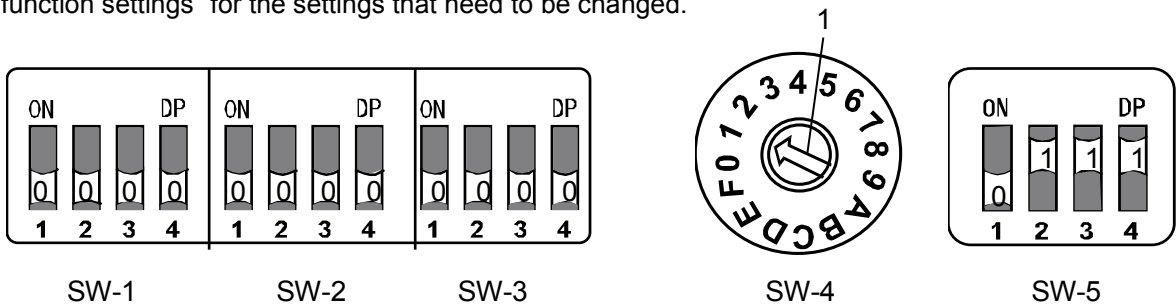

Item	Factory setting value	Switch status at factory setting		
RS-485 baud rate	9600	SW-1 No1 : 0	SW-1 No2 : 0	
RS-485 parity	EVEN	SW-1 No3 : 0	SW-1 No4 : 0	
RS-232C baud rate	2400	SW-2 No1 : 0	SW-2 No2 : 0	
RS-485 communication method	Mosbus RTU mode	SW-2 No3 : 0		
Device address	01	SW-3 No3 : 0	SW-3 No4 : 0	SW-4 : 1
Terminating resistor	None	SW-5 No1 : 0		
Fixed decimal point function	AUTO	SW-5 No2 : 1	SW-5 No3 : 1	SW-5 No4 : 1

## 7-3 RS-485 function settings

### ■ Communication settings

SW-1

Baud rate : RS-485 Baud Rate	Setting status	Setting status	Parity : RS-485 Parity
9600 bps			EVEN
19200 bps			ODD
38400 bps			Setting prohibited
115200 bps			NONE

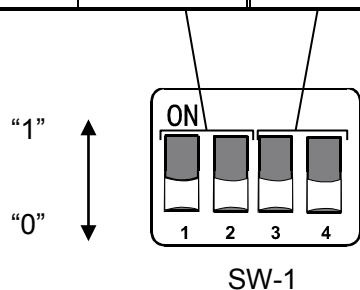

### ■ Settings for the RS-485 communication method

The RS-485 communication method of the AD-8551R can be selected from two types: communication using Modbus RTU (Modbus RTU mode) and communication using ASCII code (command mode).

SW-2 No.3

RS-485 communication method: Mode	Setting status
Modbus RTU mode	
Command mode	

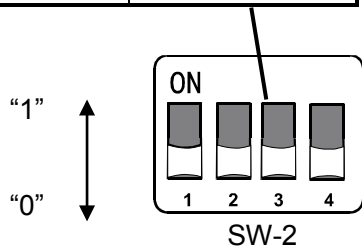

■ Device address allocation

Allocate a device address for each AD-8551R.

Device address allocation can be set from 01 to 63 using switches (SW-3, 4).

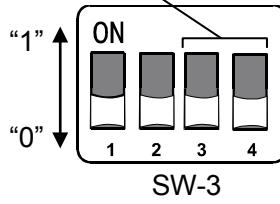
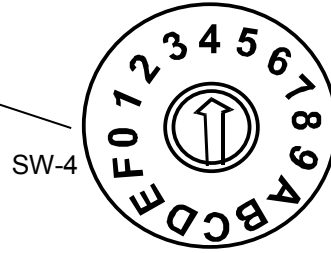

SW-2 No. 4, ADDRESS

Device Address	Setting status	
	SW-3	SW-4
Setting prohibited		0
01		1
02		2
03		3
04		4
05		5
06		6
07		7
08		8
09		9
10		A
11		B
12		C
13		D
14		E
15		F
16		0
17		1
18		2
19		3
20		4
21		5
22		6
23		7
24		8
25		9
26		A
27		B
28		C
29		D
30		E
31		F
32		0
33		1
34		2
35		3
36		4
37		5
38		6
39		7
40		8
41		9
42		A
43		B
44		C
45		D
46		E
47		F
48		0
49		1
50		2
51		3
52		4
53		5
54		6
55		7
56		8
57		9
58		A
59		B
60		C
61		D
62		E
63		F



## Terminating resistor selection

SW-5 No.1

Terminating Resistor	Setting status
No terminating resistor	
With terminating resistor (Between [DATA+] and [DATA-] is 100Ω)	

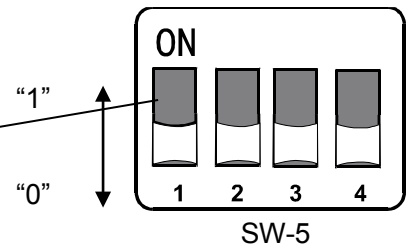

Example when several units are connected.

Connect termination resistors only at the ends of the network.

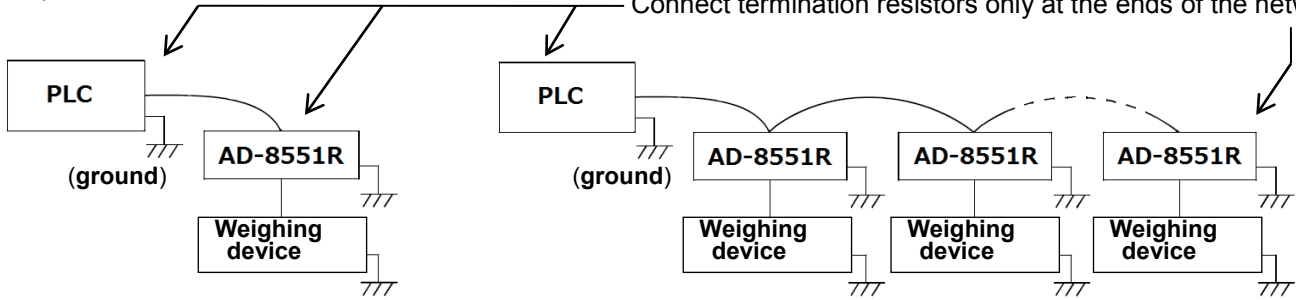





Single connection

Multi drop connection

## 7-4 RS-232C function settings

### Communication setting

SW-2 No.1, No.2

Baud rate : RS-232C Baud Rate	Setting state
2400bsp	
4800bps	
9600bps	
19200bps	

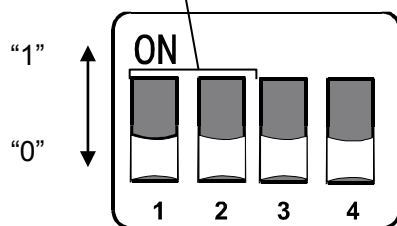

## 7-5 Fixed decimal point function

- The fixed decimal point function is valid only in Modbus RTU mode.
- If the connected weighing device has a smart range function, the number of digits after the decimal point is automatically changed.

If you want to fix the number of digits, use the fixed decimal point function.

Example of storage format with fixed decimal point function

Weighing device output value	Setting of decimal point position	AD8551R internal data	
		Weighing value (Holding Register: 40 2001 to 2002)	Decimal point position (Holding Register: 40 2005 to 2006)
123.456g	2	12345	2
	3	123456	3
	AUTO* <sup>1</sup>	123456	3
123.45g	2	12345	2
	3	123450	3
	AUTO* <sup>1</sup>	12345	2

SW-5 No. 2 to No. 4

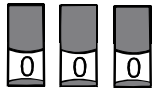
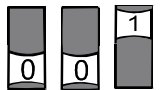
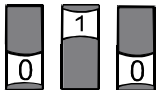
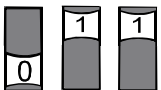
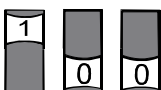
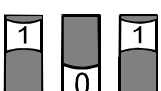
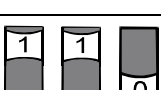
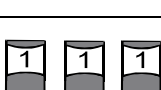
Setting of decimal point position: Decimal Point	Setting state
0	
1	
2	
3	
4	
5	
6	
AUTO* <sup>1</sup>	

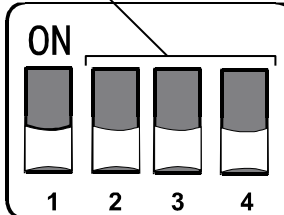

SW-5

- \* 1. Depending on the output of the weighing device, the number of digits stored in the weighing value (Holding Register: 40 2001 to 2002) and the decimal point position (Holding Register: 40 2005 to 2006) are automatically switched.

## 8. LED (status, error display)

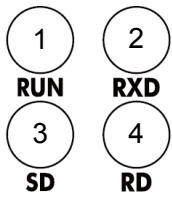

Place	Display	Color	Status
1	RUN	Blue	Illuminates when the AD-8551R is powered on. Flashes when the RS-485 or RS-232C communication settings are incorrect. (Refer to the following "RUN illumination status (Error display)")
2	RXD	Yellow	Flashes when the AD-8551R receives data from the weighing device.
3	SD	Green	Flashes when the AD-8551R is transmitting data to the host.
4	RD	Orange	Flashes when the AD-8551R is receiving data from the host (PLC, PC, etc.)

### ■ RUN Flashes status (Error display)

RUN illumination status	Status
Always illuminated	No communication error
Fast flashing (0.1 second period)	RS-485 communication error
Slow flashing (2 second period)	RS-232C communication error

Illumination timing at time of error

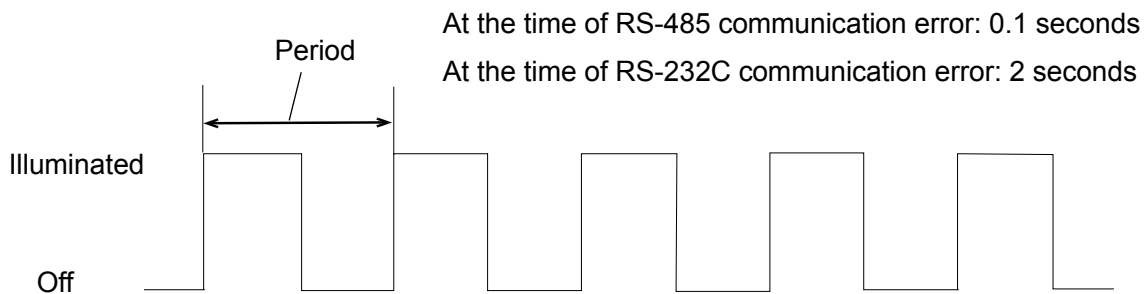

### Caution

- Communication errors can be detected as framing errors, parity errors, and overrun errors.
- If an error is detected in both RS-485 and RS-232C, RUN illumination status is fast flashing.  
(Prioritize RS-485 communication errors)

## 9. Communicaiton in Modbus RTU Mode

- Weighing value reading and zero reset (re-zero) are possible.
- When using the following models, calibration (sensitivity adjustment) is possible via Mdbus RTU.  
When calibrating with a weighing device rather than the ones listed below, use the key, etc. of the weighing device while looking at the display of the weighing device.

Applicable model	Sensitivity adjustment method	Outline of procedure
AD-4212C	External weight <sup>*1</sup>	While monitoring the balance status with the Holding Register, it is necessary to instruct data acquisition by Coil and to load and unload the weight on the weighing instrument.
AD-4212D	External weight <sup>*1</sup>	
	Built-in weight	After instruction by Coil, the holding register monitors until calibration is completed.

\* 1 . When changing the weight value to be used, refer to the instruction manual of the individual weighing device.

### ■ Notes on Modbus RTU communication with AD-8551R.

- The function codes and maximum number that can be supported by AD-8551R are as follows.

Code	Function name
01	Read Coils
03	Read Holding Registers
05	Force Single Coil
15	Force Multiple Coils <sup>*2</sup>

\* 2 . This is possible only when the number of Coils to be rewritten is one.

### Caution

Rewriting of Holding Register is not supported.

## 9-1 Preparing for communication

- ① Set the following setting items so that the RS-232C of the weighing instrument and AD-8551R are the same.

Reference: AD-4212C / AD-4212D factory setting

Setting item	Weighing device	AD-8551R
Baud rate	2400*, 4800, 9600, 19200 bps	
Data bit	7 bit*	
Parity	EVEN*	
Stop bit	1 bit*	
Terminator	<CR><LF>*	
Data output format	A&D standard format*	—
Data output mode	Settings for continuous output of weighing values. (stream mode*)	—

\* AD-8551R factory setting (normally, the factory setting of AD-4212C / AD-4212D is the same.)

- ② Set the following setting items so that the RS-485 of the host (PLC, PC, etc.) and AD-8551R are the same.

Setting item	Host (PLC, PC.etc)	AD-8551R
Baud rate	9600*, 19200, 38400, 115200 bps	
Data bit	8 bit*	
Parity	EVEN*, ODD, NONE	
Stop bit	1 bit*	
Terminator	No communication for 3.5 characters*	

- ③ Refer to "4-2 Connecting example", "5-2 Connections", "6-2 Connecting cable" for connecting.
- Normally, when using the AD-4212C/AD-4212D, power can be supplied from the RS-232C terminal, so connecting to the power terminal is not required.
  - When connecting to the AD-4212D in Modbus RTU mode, connect to the AD-8551R using the AD-4212D display connector.
- ④ Turn on the device power.
- Turn on the AD-8551R and the weighing device at the same time (within approximately 1 second) or turn on the AD-8551R first. If the AD-8551R power is turned on late, the response characteristics (Holding Register: 40 2015-2016) may not operate correctly.

## 9-2 Data address

### Caution

The data address is described in the following two ways.

**Absolute address:** The address where the data is stored.

**Communication address:** Start address for communication in Modbus RTU

When communicating with Modbus RTU, the start address must be one less than the address of the data to be read/written.

(For details of communication contents, refer to “9-5 Communication format”.)

Some communication software automatically sends one less than the address when communicating when an absolute address is specified.

### ■ Coil address map

Data address (Coil)		R/W	Item	Description
Absolute address	Communication address (decimal)			
00	2001	0x07D0 (2000)	“EXC” command output	Use for calibration (sensitivity adjustment)
	2002	0x07D1 (2001)	“CAL” command output	
	2003	0x07D2 (2002)	“PRT” command output	
	2004	0x07D3 (2003)	“R” command output	Performs zero reset (re-zero) of weighing value
	2005	0x07D4 (2004)	“SMP” command output	Changes the minimum display of the weighing device
	2006	0x07D5 (2005)	“U” command output*2	Changes response characteristics or switching units
	2007	0x07D6 (2006)	“RZ” command output	Performs zero reset (re-zero) of weighing value
	2008	0x07D7 (2007)	“Z” command output	

★ 1. When “1” is written, the AD-8551R outputs each command to the connected weighing device and returns the Coil status to “0”. “0” is output when performing reading.

★ 2. The operation differs depending on the weighing device. Refer to “3-2 Applicable models” or the operation manual of the individual weighing device for the operation with that weighing device.

### ■ Holding Register address map

Data address ( Holding Register )		R/W	Item	Description
Absolute address	Communication address (Decimal number)			
40	2001	0x07D0 (2000)	Weighing value (Lower)	32 bit binary representation
	2002	0x07D1 (2001)	Weighing value (Upper)	
	2003	0x07D2 (2002)	Status information (Lower)*4	
	2004	0x07D3 (2003)	Status information (Upper)*4	
	2005	0x07D4 (2004)	Decimal point position (Lower)	32 bit binary representation
	2006	0x07D5 (2005)	Decimal point position (Upper)	
	2007~2012	0x07D6~0x07DB (2006~20011)		No function
	2013	0x07DC (2012)	Weighing unit (Lower)	32 bit binary representation
	2014	0x07DD (2013)	Weighing unit (Upper)	
	2015	0x07DE (2014)	Response characteristics (Lower)*5	32 bit binary representation
	2016	0x07DF (2015)	Response characteristics (Upper)*5	
	2017	0x07E0 (2016)	Calibration status (Lower)*5	32 bit binary representation
	2018	0x07E1 (2017)	Calibration status (Upper)*5	
	2019	0x07E2 (2018)	Calibration weight value (Lower) *5	32 bit binary representation
	2020	0x07E3 (2019)	Calibration weight value (Upper) *5	

★3. It cannot be rewritten by writing from the master.

★4. The function is limited if connected to other than AD-4212C/D.

★5. Can be used only when connected to the AD-4212C/D.

## 9-3 Detailed information on Holding Register 1

### ■ Weighing value (Holding Register: 40 2001 to 2002), decimal point position (Holding Register :40 2005 to 2006)

Example of weighing value and decimal point position value by weighing device output.

(When the decimal point position by SW-5 is set to AUTO.)

Output value	Data address (Holding Register)	Data	Description
123.456g	40	2001	0xE240
		2002	0x0001
		2005	0x0003
		2006	0x0000
			Weighing value 0x0001E240 ⇒ 123456
			Decimal point position 0x00000003 ⇒ 3
123.45g	40	2001	0x3039
		2002	0x0000
		2005	0x0002
		2006	0x0000
			Weighing value 0x00003039 ⇒ 12345
			Decimal point position 0x00000002 ⇒ 2

### ■ Status information of weighing value (Holding Register: 40 2003 to 2004)

Data Address (Holding Register)	Item	Description
40	2003.00	Stable / Unstable state of weighing value 0: Unstable 1: Stable
	2003.01	Weighing range over flag 1: When the weighing value exceeds the maximum display.
	2003.02	Non-weighing status flag 0: When the current weighing value is received from the weighing device. 1: When the weighing value is interrupted for more than 2 seconds, re-zero or calibration is in progress.
	2003.03	Re-zero flag 1: Processing rezero* <sup>1</sup>
	2003.04	No function
	2003.05	Calibration in progress flag 1: During calibration process* <sup>1</sup>
	2003.06	Calibration error flag* <sup>2</sup> 1: If the measured calibration weight value is not appropriate during calibration. (It returns to "0" when the weighing mode is entered.)
	2003.07 to 15	No function
	2004.01 to 15	

\* 1 . Flag does not change when operated with keys of the weighing device.

\* 2 . Can be used only when connected to AD-4212C / D.

#### Caution

Be sure to read "weighing value" and "weighing value status information" at the same time.

If they are read separately, depending on the update timing, the correspondence between the "weighing value" and "weighing value status information" may be different, so the status of the weighing value cannot be determined.

### ■ Weighing unit (Holding Register: 40 2013 to 2014)

Relationship between stored value and unit

Value	Weighing unit (mode)	Value	Weighing unit (mode)	Value	Weighing unit (mode)
0x00000000	g (gram)	0x00000006	mom (Momme)	0x0000000C	TL (Tael)
0x00000001	mg (milligram)	0x00000007	OZ (Ounce)	0x0000000D	Tol (Tola)
0x00000002	kg (kilogram)	0x00000008	Lb (Pound)	0x0000000E	MES (Messghal)
0x00000003	PCS (pieces)	0x00000009	OZt (Troy Ounce)	0x0000000F	N (Newton)
0x00000004	% (percent)	0x0000000A	dwt (Pennyweight)	0x00000010	MLT (Programmable unit)
0x00000005	ct (carat)	0x0000000B	GN (Grain)	0xFFFFFFFF	Indistinguishable

## 9-4 Detailed information on Holding Register 2 (only for AD-4212C/AD-4212D)

The following items change only when connected to the the AD-4212C / AD-4212D.

When connected to another measuring instrument, they will be the initial values.

### ■ Response characteristics (Holding Register: 40 2015 to 2016)

Value	Response characteristic status*1
0x00000000	Default value
0x00000001	FAST
0x00000002	MID
0x00000003	SLOW
0x00000004	User setting*2

\* 1 . FAST / MID / SLOW can be switched by writing "1" to Coil 00 2006.

\* 2 . AD-4212C with fine response characteristics.

(Refer to WinCT-AD4212C additional instruction manual for setting method.)

### ■ Calibration status (Holding Register: 40 2017 to 2018)

Value	Response characteristic status
0x00000000	Default value
0x00000001	Waiting for zero point weighing
0x00000002	Weighing zero point
0x00000003	Waiting for weighing of calibration weight
0x00000004	Weighing calibration weight
0x00000005	Calibration completed
0x00000006	Calibration error

### ■ Calibration weight value (Holding Register: 40 2019 to 2020)

When executing calibration (sensitivity adjustment) with your own weight, the value of the calibration weight can be checked.

- The unit is gram and the decimal point is none.

- Only when "Waiting weighing of calibration weight" is the value of the calibration weight to be used.

The initial value is "0xFFFFFFFF". When returning to the weighing mode, it will return to the initial value.

Calibration weight value to be used	Data Address (Holding Register)	Data	Description
100g	40	2019	0x0064
		2020	0x0000
			Calibration weight value 0x00000064 ⇒ 100

## 9-5 Communication format

This is the format for communication between the AD-8551R and a host (PLC, PC, etc.) with Modbus RTU.

If communication between the host (PLC,PC, etc.) and AD-8551R is not possible, send the contents of the following example from the host and check the communication.

### ■When writing to Coil

#### Operation details

Write 1 to Coil 00 2004 of the AD-8551R where device address is 01 (Rezero instruction to the weighing instrument).

#### Sent from the master

Field name	Example (Hexadecimal)	Description
Header	None (No communication for 3.5 characters)	
Device address	0x01	
Function code	0x05	
Start address(Upper)	0x07	0x07D3 = 2003 (Note that address for communication is 1 less.)
Start address(Lower)	0xD3	
Conversion data(Upper)	0xFF	
Conversion data(Lower)	0x00	
Error check	0x7CB7	
Trailer	None (No communication for 3.5 characters)	

#### Response from the device

Field name	Example (Hexadecimal)	Description
Header	None (No communication for 3.5 characters)	
Device address	0x01	
Function code	0x05	
Start address(Upper)	0x07	0x07D3 = 2003 (Note that address for communication)
Start address(Lower)	0xD3	
Conversion data(Upper)	0xFF	
Conversion data(Lower)	0x00	
Error check	0x7CB7	
Trailer	None (No communication for 3.5 characters)	

## ■ Holding Register read communication example

### How to operate

Read 40 2001 to 2002 Holding Register of the AD-8551R where device address is 01 (Read the weighing value of the weighing device).

### Sent from the master

Field name	Example (Hexadecimal)	Description
Header	None (No communication for 3.5 characters)	
Device address	0x01	
Function code	0x03	
Start address(Upper)	0x07	0x07D0 = 2000 (Note that there are 40 0001 fewer addresses for communication)
Start address(Lower)	0xD0	
Conversion data (Upper)	0x00	
Conversion data(Lower)	0x02	
Error check	0xC486	
Trailer	None (No communication for 3.5 characters)	

### Response from the device

Field name	Example (Hexadecimal)	Description
Header	None (No communication for 3.5 characters)	
Device address	0x01	
Function code	0x03	
Number of data bytes	0x04	
Data 1(Upper)	0xD6	Weighing value : 0x0012D687 = 1234567
Data 1 (Lower)	0x87	
Data 2(Upper)	0x00	
Data 2 (Lower)	0x12	
Error check	0xF25F	
Trailer	None (No communication for 3.5 characters)	

## 9-6 Operating example (When connected to the AD-4212C/AD-4212D)

This is the procedure for basic operation of the weighing device in Modbus RTU communication.

### ■ Reading weighing value

Procedure	Contents	Modbus RTU access method	Coil address		Applicable Holding Register address	Status confirmation contents
			AD-4212C	AD-4212D	() data length	
1	Check decimal point position	Read the applicable Holding Register			40 2005-2006 (2word)	Check decimal point position eg) 0x00000003 → decimal point 3 digits
2	Check unit	Read the applicable Holding Register			40 2013-2014 (2word)	Check the applicable weighing unit from the value eg) 0x00000000 → unit : g
3	Check weighing value *1	Read the applicable Holding Register			40 2001-2002 (2word)	Check the weighing value eg) 0x00BC614E → 12345678
					40 2003-2003 (1word)	Check the status information eg) 0x0001 → stable weighing value
4	Check the weighing value by following steps 1 to 3.					
5	Repeat steps 3 to 4. *2					

★ 1 Be sure to read “weighing value” and “weighing value status information” at the same time.

If they are read separately, the weighing value status cannot be judged because the correspondence between the “weighing value” and “weighing value status information” may differ depending on the update timing.

★ 2 If the decimal point position or unit is changed, or if the smart range function is used, perform step 1 and 2 as necessary.

### ■ Re-zero (zero reset execution example)

Procedure	Contents	Modbus RTU access method	Coil address		Applicable Holding Register address	Status confirmation contents
			AD-4212C	AD-4212D	() data length	
1	Instruct to start Re-zero	Set “1” to the applicable Coil	00 2004			
2	Confirm start of Re-zero	Read applicable Holding Register			40 2003 (1word)	Wait until “40 2003.03” becomes to “1” *3
3	Confirm during Re-zero	Read applicable Holding Register			40 2003 (1word)	Wait until “40 2003.03” becomes to “0”
4	Confirm Re-zero completion	Read applicable Holding Register			40 2001-2002 (2word)	Confirm that it becomes “0x00000000” *4

★ 3. Normally, changes immediately after setting “1” to Coil in the previous step.

★ 4. If weighing value is unstable, re-zero cannot be executed. Be sure to confirm completion of re-zero by confirming that the weighing value is “0x00000000”.

■ Example of calibration (sensitivity adjustment) with external weight (Possible only with AD-4212C / AD-4212D)

Procedure	Contents	Modbus RTU access method	Coil address		Holding Register address	Status confirmation contents
			AD-4212C	AD-4212D	() data length	
1	Instruct start calibration mode	Set "1" to the applicable Coil	00 2002	00 2001		
2	Confirm calibration mode	Read applicable Holding Register			40 2017-2018 (2word)	Wait until "0x00000001" *1
3	Instruct to start weighing at zero point	Set "1" to the applicable Coil	00 2003			
4	Confirm start weighing at zero point	Read applicable Holding Register			40 2017-2018 (2word)	Wait until "0x00000002" *1
5	Confirm that zero point is being weighed.	Read applicable Holding Register			40 2017-2018 (2word)	Wait until "0x00000003" *2
6	Confirm the calibration weight value to be used *4	Read applicable Holding Register			40 2019-2020 (2word)	
7	Place calibration weight					
8	Instruct the start of weighing the calibration weight	Set "1" to the applicable Coil	00 2003			
9	Confirm weighing of calibration weight	Read applicable Holding Register			40 2017-2018 (2word)	Wait until "0x00000004" *1
10	Confirm that calibration weight is being weighed.	Read applicable Holding Register			40 2017-2018 (2word)	Wait until "0x00000005" *2*3
11	Remove calibration weight					
12	Confirm transition to weighing status	Read applicable Holding Register			40 2017-2018 (2word)	Wait until "0x00000000"

- ★ 1 . Normally, changes immediately after setting "1" to Coil in the previous step.
- ★ 2 . If the weighing device is unstable, sensitivity adjustment is not performed and it automatically shifts to weighing status (0x00000000).
- ★ 3 . If the weighed calibration weight value is not appropriate, calibration error (0x00000006) will occur. After that, it automatically shifts to weighing status (0x00000000).
- ★ 4 . If you want to change the value of the calibration weight to be used, confirm the instruction manual of the individual weighing device.

■ Example of calibration (sensitivity adjustment) with built-in weight (Possible only with AD-4212D)

Procedure	Contents	Modbus RTU access method	Applicable Coil address		Applicable Holding Register address	Status confirmation contents
			AD-4212C	AD-4212D	() data length	
1	Instruct to start calibration with internal weight	Set "1" to the applicable Coil		00 2002		
2	Confirm start of calibration	Read applicable Holding Register			40 2003 (1 word)	Wait until "40 2003.05" becomes "1" *5
3	Confirm the end of calibration	Read applicable Holding Register			40 2003 (1 word) 40 2017-2018 (2 word)	Wait until "40 2003.05" becomes "0" Confirms that "40 2017-2018" becomes "0x00000005" *6

- ★ 5 . Normally, changes immediately after setting "1" to Coil in the previous step.
- ★ 6 . If the weighing value is unstable, calibration completed (0x00000005) is not entered, and it switches automatically to weighing mode. Also, if the weighing value is not appropriate, calibration error (0x00000006) will occur. After that, it automatically shifts to weighing status (0x00000000).

# 10. Communication in Command Mode

- Normally, one-to-many communication is enabled by adding a device address to the command communication when performing one-to-one with the weighing device via RS-232C.
- The available commands are the same as the RS-232C commands for each weighing device. For details, refer to the instruction manual of the individual weighing device.

## Caution

If multiple data is output from the weighing device at one time (time and date are added to the weighing value, etc.), data loss may occur.

## 10-1 Preparing for communication

- ① Set the following setting items so that the RS-232C of the weighing device and AD-8551R are the same.

Reference: Factory setting of the AD-4212C / AD-4212D

Setting item	Weighing device	AD-8551R
Baud rate	2400*, 4800, 9600, 19200 bps	
Data bit	7 bit*	
Parity	EVEN*	
Stop bit	1 bit*	
Terminator	<CR><LF>*	
Data output format	A&D standard format*	—
Data output mode *1, *2	Setting to output the weighing value with an external command. (key mode, etc.)	—

\* Factory setting of the AD-8551R (normally, factory settings of AD-4212C/AD-4212D are same)

\* 1 . If each weighing device is set to automatically output data (auto print, interval mode, etc), multiple devices may communicate simultaneously with RS-485 and may not communicate normally.

\* 2 . With the AD-4212C, it is necessary to change the data output mode.

(Refer to the individual device instruction manual for how to change.)

- ② Set the following setting items so that the RS-485 of the host (PLC, PC, etc.) and AD-8551R are the same.

Setting item	Host (PLC, PC, etc)	AD-8551R
Baud rate	9600*, 19200, 38400, 115200 bps	
Data bit	8 bit*	
Parity	EVEN*, ODD, NONE	
Stop bit	1 bit*	
Terminator	<CR><LF>*	

- ③ Refer to "4-2 Connecting example", "5-2 Connections", "6-2 Connecting cable" for connecting.

- Normally, when using the AD-4212C, power can be supplied from the RS-232C terminal, so connecting to the power terminal is not required.
- When connecting to the AD-4212D in command mode, connect to the AD-8551R using the AD-4212D PLC connector.

- ⑤ Turn on the power for each device.

## 10-2 Communication format

- Format sent from the host (PLC, PC, etc.).

Add "@\*\*" ("\*\*" is the device address 01 to 63 set with AD-8551R) before the command you want to send to the weighing device.

The AD-8551R with the matching device address outputs the command part excluding "@\*\*" to the weighing device (RS-232C) side.

- Format received by the host (PLC, PC, etc.).

A command with "@\*\*" ("\*\*" is the device address 01 to 63 set by AD-8551R) added before the data output from the weighing device is received.

### ■ Example of obtaining weighing data from a weighing instrument connected to device address 01.

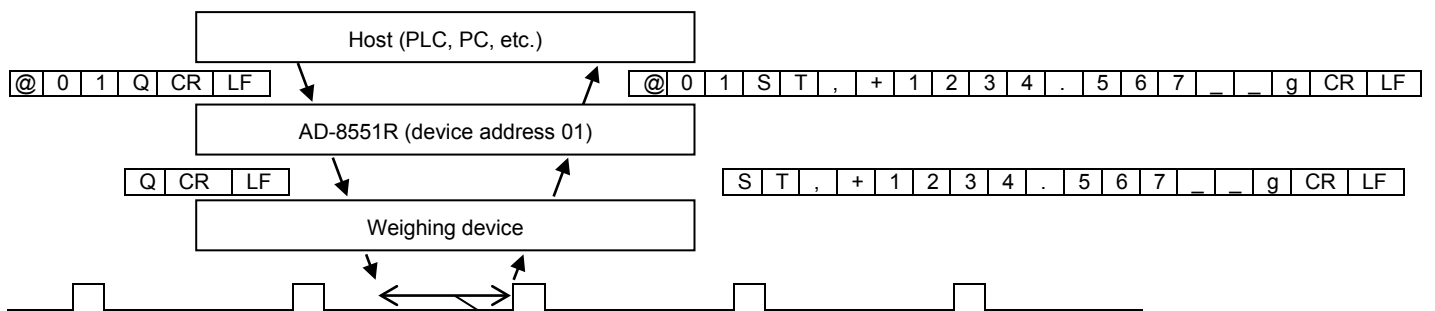

Timing of display rewriting of the weighing device

Wait for display rewriting : After receiving the data request command, the weighing device outputs the weighing value at the timing of rewriting the display.

### ■ Example of re-zeroing the weighing instrument connected to device address 01.

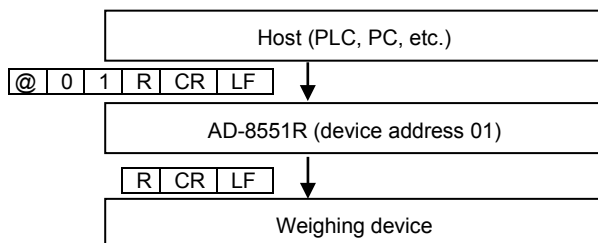

### Caution

Some weighing devices do not respond to requests for weighing data during rezero processing. Wait for the rezero process to finish and request the weighing data again.

# 11. Troubleshooting

## 11-1 Modbus RTU mode communication check

Phenomenon	Confirmation and countermeasures
RUN LED does not illuminate.	Confirm that the power supply is correctly supplied to the power supply terminal of the AD-8551R. <ul style="list-style-type: none"> <li>• Is the voltage appropriate? (12 to 24 VDC)</li> <li>• Is the cable connected correctly?</li> </ul>
RXD LED does not flash.	Confirm that the weighing device is connected and set correctly. <ul style="list-style-type: none"> <li>• Is the cable properly connected to the RS-232C terminal?</li> <li>• Is the proper cable used?</li> <li>• Is the data output from the weighing device? (Set the weighing device to stream mode.)</li> <li>• Is the weighing device in weighing mode? (Is the display off, CAL mode on internal setting mode, etc?)</li> </ul>
RD LED does not flash.	Confirm that the connection with the host is correct. <ul style="list-style-type: none"> <li>• Is the cable properly connected to the RS-485 terminal?</li> <li>• Is a signal output from the host?</li> </ul>
RUN LED is flashing.	RS-232C or RS-485 communication error. Confirm whether RS-232C or RS-485 is in error* <sup>1</sup> and change the communication settings.
SD LED does not flash.	Confirm the signal contents from the host. <ul style="list-style-type: none"> <li>• Is the AD-8551R set to command mode?</li> <li>• Does the device address specified on the host side match the device address set on the AD-8551R?</li> <li>• Is the content sent from the host suitable for the command mode format? Send the same content as "9-5 Communication format" from the host.</li> </ul>
The data received by the host is corrupted.	Are multiple AD-8551R set to the same device address?
Non-weighing status flag is "1".	Confirm the settings of the weighing device. <ul style="list-style-type: none"> <li>• Is the RUN LED flashing slowly (RS-232C communication error)*<sup>1</sup> ? Confirm the RS-232C communication settings.</li> <li>• Is the weighing device output format set to the A&amp;D standard format.</li> </ul>
AD-8551R settings cannot be changed.	Turn the AD-8551R off and the on again. When the power is turned on, the switch status is read and reflected in the operation.

\* 1 . Refer to "8. LED (status, error display)".

## 11-2 Command mode communication check

Phenomenon	Confirmation and countermeasures
RUN LED does not illuminate.	Confirm that the power supply is correctly supplied to the power supply terminal of the AD-8551R. <ul style="list-style-type: none"> <li>• Is the voltage appropriate? (12 to 24 VDC)</li> <li>• Is the cable connected correctly?</li> </ul>
The RXD LED flashes before giving instructions from the host.	Confirm the setting of the weighing device. <ul style="list-style-type: none"> <li>• Is the data output mode set to key mode?</li> </ul>
RD LED does not flash.	Confirm that the connection with the host is correct. <ul style="list-style-type: none"> <li>• Is the cable properly connected to the RS-485 terminal?</li> <li>• Is a signal output from the host?</li> </ul>
RUN LED is flashing.	RS-232C or RS-485 communication error. Confirm whether RS-232C or RS-485 is in error* <sup>1</sup> and change the communication settings.
RXD LED does not flash.	Confirm the signal contents from the host. <ul style="list-style-type: none"> <li>• Is the AD-8551R set to command mode?</li> <li>• Does the device address specified on the host side match the device address set in the AD-8551R?</li> <li>• Is the content sent from the host suitable for the command mode format? Send the same content as "10-2 Communication format" from the host.</li> </ul> Confirm that the weighing device is connected and set correctly. <ul style="list-style-type: none"> <li>• Is the cable properly connected to the RS-232C terminal?</li> <li>• Is the correct cable used?</li> <li>• Is the weighing device in weighing mode? (Is the display off, CAL mode or internal setting mode, etc?)</li> </ul>
The data received by the host is corrupted.	<ul style="list-style-type: none"> <li>• Are multiple AD-8551R set to the same device address?</li> <li>• After outputting a data request command to the weighing device, is the next command output without waiting for the receipt of weighing data?</li> <li>• Is the data output mode of the other weighing device set to key mode?</li> </ul>
AD-8551R settings cannot be changed.	Turn the AD-8551R off and the on again. When the power is turned on, the switch status is read and reflected in the operation.

\* 1 . Refer to "8. LED (status, error display)"



#### **A&D Company, Limited**

3-23-14 Higashi-Ikebukuro, Toshima-ku, Tokyo 170-0013, JAPAN  
Telephone: [81] (3) 5391-6132 Fax: [81] (3) 5391-1566

#### **A&D ENGINEERING, INC.**

1756 Automation Parkway, San Jose, California 95131, U.S.A.  
Telephone: [1] (408) 263-5333 Fax: [1] (408) 263-0119

#### **A&D INSTRUMENTS LIMITED**

Unit 24/26 Blacklands Way, Abingdon Business Park, Abingdon, Oxfordshire OX14 1DY United Kingdom  
Telephone: [44] (1235) 550420 Fax: [44] (1235) 550485

#### **A&D AUSTRALASIA PTY LTD**

32 Dew Street, Thebarton, South Australia 5031, AUSTRALIA  
Telephone: [61] (8) 8301-8100 Fax: [61] (8) 8352-7409

#### **A&D KOREA Limited**

한국에이.엔.디(주)  
서울특별시 영등포구 국제금융로6길33 (여의도동) 맨하탄빌딩 817 우편 번호 07331  
( 817, Manhattan Bldg., 33. Gukjegeumyung-ro 6-gil, Yeongdeungpo-gu, Seoul, 07331 Korea )  
전화: [82] (2) 780-4101 팩스: [82] (2) 782-4264

#### **OOO A&D RUS**

ООО "ЭЙ энд ДИ РУС"  
121357, Российская Федерация, г.Москва, ул. Вереysкая, дом 17  
( Business-Center "Vereyskaya Plaza-2" 121357, Russian Federation, Moscow, Vereyskaya Street 17 )  
тел.: [7] (495) 937-33-44 факс: [7] (495) 937-55-66

#### **A&D INSTRUMENTS INDIA PRIVATE LIMITED**

509, उद्योग विहार , फेस -5, गुडगांव - 122016, हरियाणा , भारत  
( 509, Udyog Vihar, Phase-V, Gurgaon - 122 016, Haryana, India )  
फोन : 91-124-4715555 फैक्स : 91-124-4715599

#### **ऐ&डी इन्स्ट्रुमेंट्स इण्डिया प्रा० लिमिटेड**